

# ***Beverly Display Solutions***

**Module No. : BD070RDH13**

**Revision : Ver 1.0**

**Customer \_\_\_\_\_**

Approved By	Date	Notes



## CONTENTS

No	ITEM	PAGE
1	General Description	4
2	Mechanical Specifications	4
3	Interface signals	6
4	Absolute Maximum Ratings	7
4.1	Electrical Maximum Ratings - FOR IC ONLY	7
4.2	Environmental Condition	7
5	Electrical Specifications	8
5.1	Typical Electrical Characteristics	8
5.2	TFT Panel Timing Characteristics	9
6	Optical Characteristics (for panel only)	12
7	TFT Inspection Specifications	14
8	Packing demonstrate	16
9	PRECAUTIONS FOR LCM	17

## 1. General Description

- 7.0", Normally Black with Anti-Glare, 16.7M Colors, MVA TFT dot matrix LCD module.
- Viewing Angle: 12 o'clock
- Logic Voltage : 3.3V(Type)
- Data Interface: RGB Interface.

## 2. Mechanical Specifications

The mechanical detail is shown in Fig. 2 and summarized in Table 1 below.

Table 1

Parameter	Specifications	Unit	
Outline dimensions	164.9(W) x 100.0(H) x 5.7(D)	mm	
Color TFT 240xRGBx320	Active area	154.08(W) x 85.92(H)	mm
	Display format	800 (RGB) x 480	dots
	Color configuration	RGB stripe	-
	Dot pitch	0.193 (RGB) (W) x 0.179(H)	mm
Weight	Approx 160	gram	

Note 1: Viewing direction for best image quality is different from TFT definition. There is a 180 degree shift.

Note 2: Requirements on Environmental Protection: Q/S0002

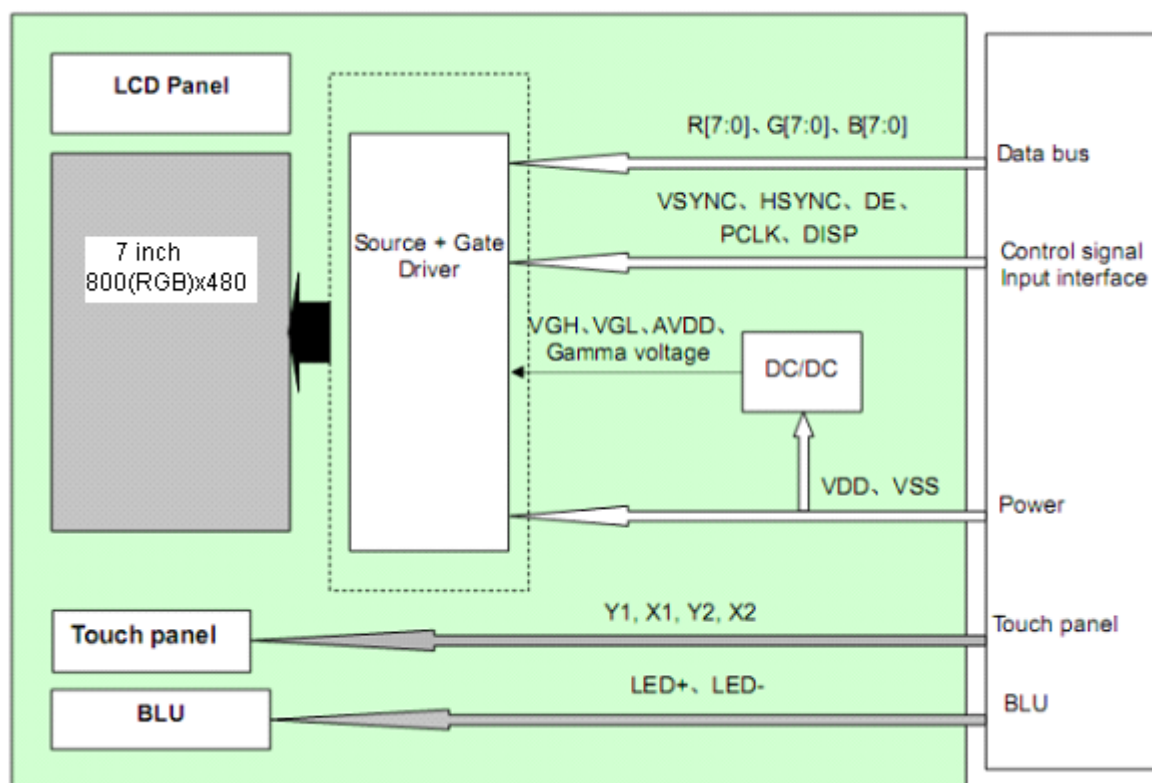

Figure 1: Block Diagram



### 3. Interface Signals

Table 2: Pin assignment

Pin No.	Symbol	Description
1,2	LEDA	Anode of LED backlight.
3,4	LEDK	Cathode of LED backlight.
5	GND	Ground.
6	Vcom	Common voltage input.
7	VDD	Power supply to the liquid crystal power supply analog circuit. Connect to an external power supply.
8	MODE	DE/SYNC mode select. H: DE mode; L: SYNC mode
9	DEN	Data Enable Signal
10	HSYNC	Horizontal Synchronous Signal
11	VSYSN	Vertical Synchronous Signal
12~19	B7~B0	Blue Data bus.
20~27	G7~G0	Green Data bus.
28~35	R7~R0	Red Data bus.
36	GND	Ground.
37	DCLK	Dot Data Clock
38	GND	Ground.
39	R/L	Set horizontal scan direction. Low/NC: left to right; High: right to left.
40	U/D	Set vertical scan direction. High/NC: up to down; Low: down to up.
41	VGH	Positive power of TFT.
42	VGL	Negative power of TFT.
43	IOVDD	Analog power supply.
44	RESET	Reset signal. Setting either pin low initializes the LSI. Must be reset after power is supplied.
45	NC	Dummy pin, Please let it float.
46	Vcom	Common voltage input.
47	DITHB	Dithering setting. H: 6 bit resolution; L: 8 bit resolution.
48	GND	Ground.
49,50	NC	Dummy pin, Please let it float.

#### UD/LR Function Description

Scan control input		Scanning direction
UD	LR	
GND	VCC	Up to down, left to right
VCC	GND	Down to up, right to left
GND	GND	Up to down, right to left
VCC	VCC	Down to up, left to right

## 4. Absolute Maximum Ratings

### 4.1 Electrical Maximum Ratings – for IC Only

Table 3

Parameter	Symbol	Min.	Max.	Unit
Power supply voltage (VDD)	IOVDD	-0.5	+15.0	V
Power supply voltage (VDD)	VDD	-0.5	+5.0	V
Back Light Forward Current	I <sub>F</sub>		50	mA
Logic input voltage	V <sub>IN</sub>	-0.3	IOVDD+0.5	V
Logic output voltage	V <sub>OUT</sub>	-0.3	IOVDD+0.5	V

Note 1: GND =0V.

Note2: No condensation allowed under any condition.

### 4.2 Environmental Condition

Table 4

Item	Operating temperature (T <sub>opr</sub> )		Storage temperature (T <sub>stg</sub> ) (Note 1)		Remark
	Min.	Max.	Min.	Max.	
Ambient temperature(T <sub>a</sub> )	-20°C	+70°C	-30°C	+80°C	Dry
Humidity (Note 1)	90% max. RH for T <sub>a</sub> ≤ 40°C < 50% RH for 40°C < T <sub>a</sub> ≤ Maximum operating temperature				No condensation
Vibration(IEC 68-2-6) cells must be mounted on a suitable connector	Frequency: 10 ~ 55 Hz Amplitude: 0.75 mm Duration: 20 cycles in each direction.				3 directions
Shock (IEC 68-2-27) Half -sine pulse shape	Pulse duration: 11 ms Peak acceleration: 981 m/s <sup>2</sup> = 100g Number of shocks: 3 shocks in 3 mutually perpendicular axes.				3 directions

Note 1: Product cannot sustain at extreme storage conditions for long time.

## 5. Electrical Specifications

### 5.1 Typical Electrical Characteristics

At Ta = 25 °C, VDD=3.3V, GND=0V.

Table 5

Parameter	Symbol	Conditions	Min.	Typ.	Max.	Unit
Supply voltage	VDD		+3.0	+3.3	+3.6	V
Analog Supply voltage	IOVDD		+9.88	+10.4	+10.92	V
Gate drive High voltage	VGH		14.4	16.0	17.6	V
Gate drive Low voltage	VGL		-7.7	-7.0	-6.3	V
Gate drive Low voltage	Vcom		+3.68	+3.7	+3.72	V
Input signal voltage	V <sub>IH</sub>	“H” level	0.7V <sub>D</sub>	-	VDD	V
	V <sub>IL</sub>	“L” level	VSS	-	0.3V <sub>D</sub>	V
Supply current	ICC+IVDD	VDD= +3.3V, Note1	-	-	30	mA
		VDD = +3.3V, Note 1	-	-	30	mA
Supply voltage of white LED backlight	VLED	Forward current =120mA(@25°C)  Number of LED dies = 18	-	9.6	10.8	V

Note 1: Do not display the fixed pattern for a long time because it may develop image sticking due to the LCD structure. It should change pattern frequently. If the screen is displayed with fixed pattern, use a screen saver.



## 5.2 TFT Panel Timing Characteristics

### 5.2.1 Input Setup Timing

At  $T_a = 25^\circ\text{C}$ ,  $\text{GND}=0\text{V}$ ,  $\text{VDD}=3.3\text{V}$ .

Parameter	Symbol	Min	Typ	Max	Unit	Remark
DCLK frequency	$F_{\text{clk}}$	28	30.0	40.0	MHz	
DCLK cycle time	$T_{\text{cph}}$	25	33.3	36	ns	
DCLK pulse width	$T_{\text{cw}}$	40%	50%	60%	$T_{\text{cph}}$	
VS setup time	$T_{\text{vst}}$	8			ns	
VS hold time	$T_{\text{vhd}}$	8	-	-	ns	
HS setup time	$T_{\text{hst}}$	8			ns	
HS hold time	$T_{\text{hhd}}$	8	-	-	ns	
Data setup time	$T_{\text{dsu}}$	8			ns	Data to DCLK
Data hold time	$T_{\text{dhd}}$	8	-	-	ns	Data to DCLK
DE setup time	$T_{\text{esu}}$	8	-	-	ns	
DE hold time	$T_{\text{ehd}}$	8	-	-	ns	

Table 6

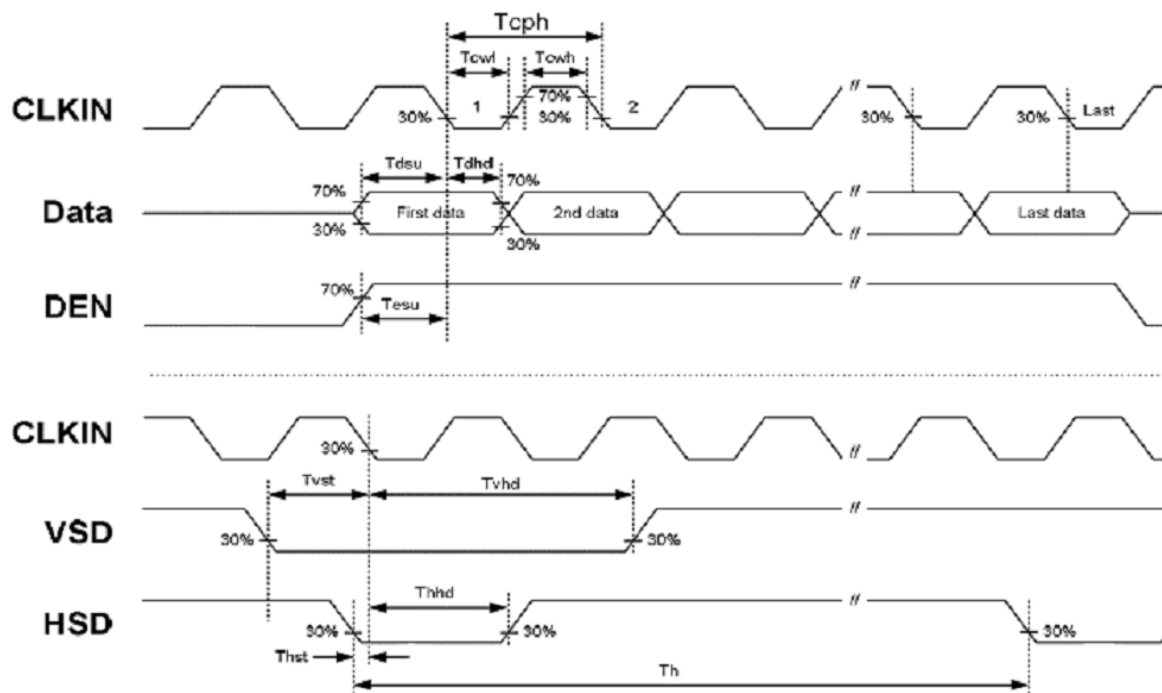

Figure 1: Input Setup Timing

### 5.2.2 Data Input Timing Parameter Setting

At Ta = 25°C, GND=0V, VDD=3.3V.

Table 7

Parameter	Symbol	Min	Typ	Max	Unit	Remark
DCLK	F <sub>clk</sub>	28	30.0	40.0	MHZ	
	t <sub>clk</sub>	25.0	33.3	36	ns	
HS	t <sub>h</sub>	889	928	1143	t <sub>clk</sub>	
	t <sub>hd</sub>	800	800	800	t <sub>clk</sub>	
	t <sub>hpw</sub>	1	48	-	t <sub>clk</sub>	
	t <sub>hb</sub>	88	88	88	t <sub>clk</sub>	
	t <sub>hfp</sub>	1	40	255	t <sub>clk</sub>	
VS	t <sub>v</sub>	513	525	767	t <sub>h</sub>	
	t <sub>vd</sub>	480	480	480	t <sub>h</sub>	
	t <sub>vpw</sub>	3	3	-	t <sub>h</sub>	
	t <sub>vb</sub>	32	32	32	t <sub>h</sub>	
	t <sub>vfp</sub>	1	13	255	t <sub>h</sub>	

Note 1: DE timing refer to HS, VS input timing.

#### TCON Vertical Input Timing Diagram HV

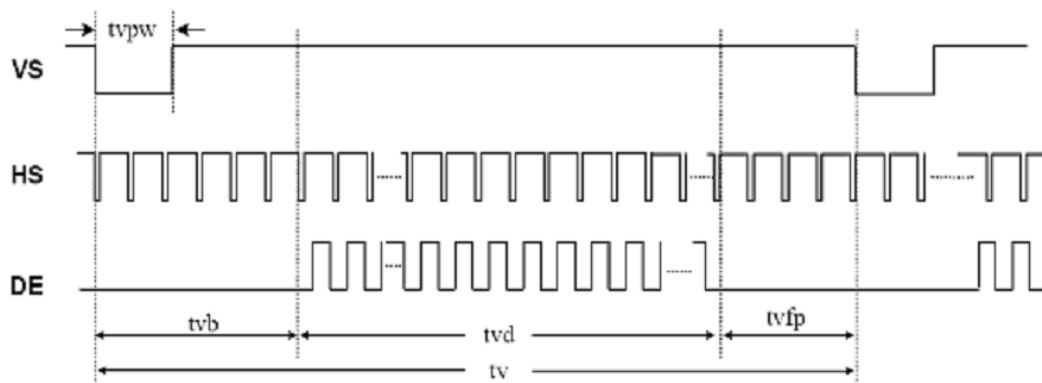

Figure 2: Data Input Timing

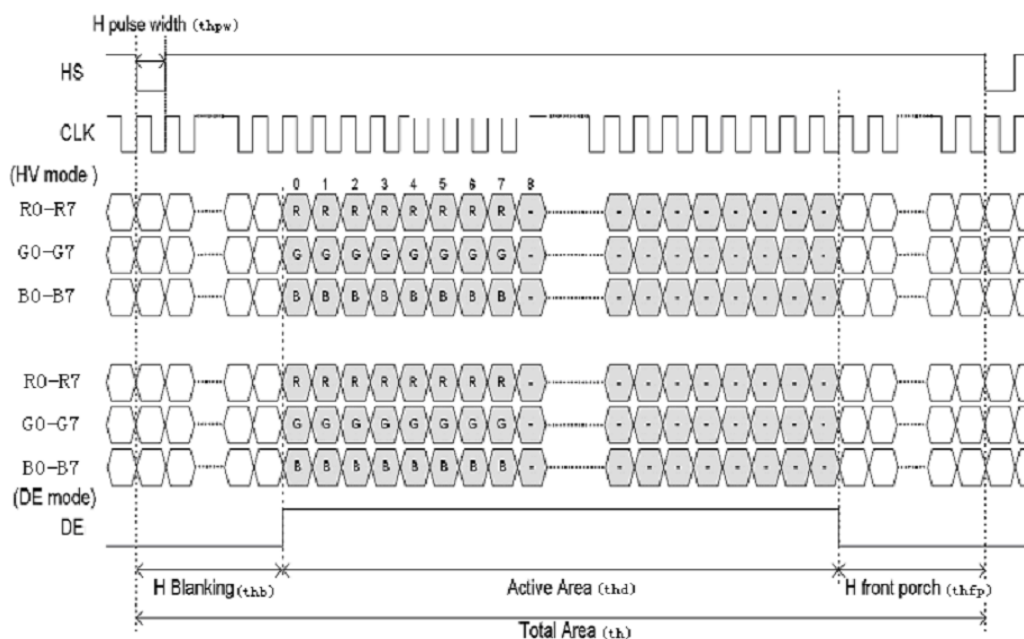

Figure 3: TCON Mode Interface Characteristics

## 6. Optical Characteristics (for panel only)

Table 8: Optical characteristics

Items	Symbol	Condition	Min.	Typ.	Max.	Unit	Note			
Response Time	$T_R + T_F$	$T_a=25^\circ\text{C}$ Viewing normal angle $\theta=\phi=0^\circ$	-	20	30	ms	(Note 1)			
Viewing angle	12'	$T_a=25^\circ\text{C}$ Center $CR \geq 10$		-	60	-	deg.	(Note 2)		
	6'			1	-	70			-	
	9'			2	-	70			-	
	3'			1	-	70			-	
Contrast Ratio	CR	$T_a=25^\circ\text{C}$ Viewing normal angle $\theta=\phi=0^\circ$	400	500	-	-	(Note 3)			
Luminance (on the module surface)	Br	$T_a=25^\circ\text{C}$	200	250	-	$\text{cd/m}^2$				
Transmittance	%		-	6.5	-	%				
Chromaticity	Red	$T_a=25^\circ\text{C}$ Viewing normal angle $\theta=\phi=0^\circ$					(Note 4)	$x_R$	0.590	-
								$y_R$	0.350	-
	Green							$x_G$	0.348	-
								$y_G$	0.580	-
	Blue							$x_B$	0.150	-
								$y_B$	0.100	-
	White							$x_W$	0.320	-
								$y_W$	0.340	-

Note 1: The electro-optical response time measurements shall be made as Figure 5 by switching the “data” input signal OFF and ON. The times needed for the luminance to change from 10% to 90% is  $T_r$ , and 90% to 10% is  $T_f$ .

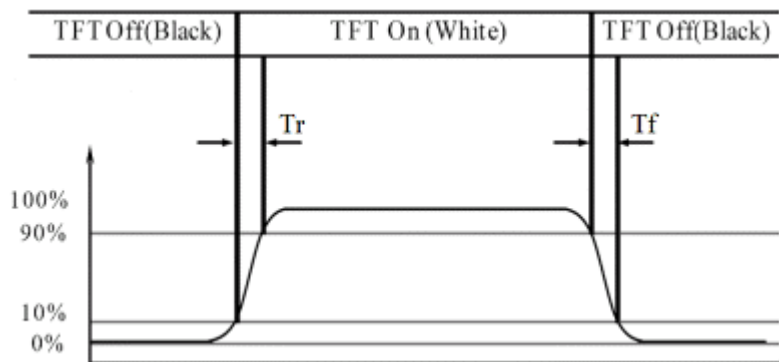

Figure 5: Response Time Testing

Note 2: The definitions of viewing angle.

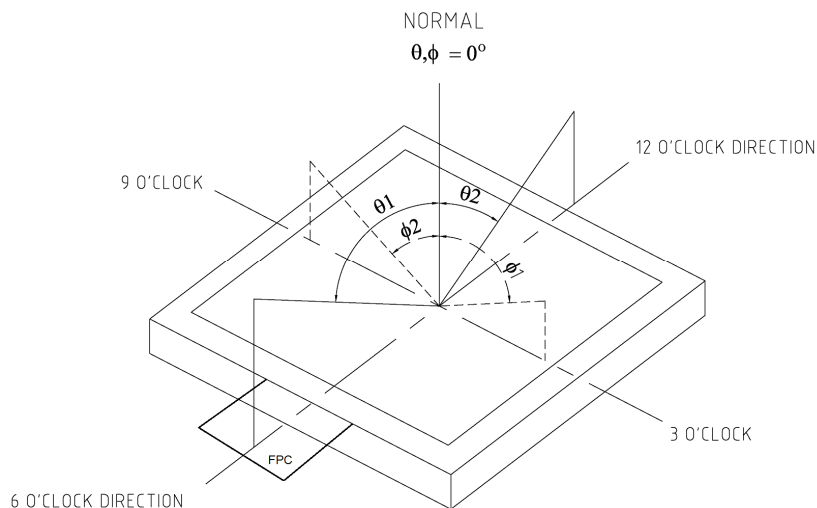

Figure 6

Note 3: Contrast measurements shall be made at viewing angle of  $\theta=0^\circ$  and at the center of the LCD surface by using DMS. Luminance shall be measured with all pixels in the view field set first to white, then to the dark (black) state. (See figure 6)

Luminance Contrast Ratio (CR) is defined mathematically.

$$CR = \frac{\text{Luminance when displaying a white raster}}{\text{Luminance when displaying a black raster}}$$

Note 4: The color chromaticity coordinates specified in Table 9 shall be updated from later actual spectral data measured with all pixels first in red, green, blue and white. Measurements shall be made at the center of the panel.

7. TFT Panel Inspection Specifications

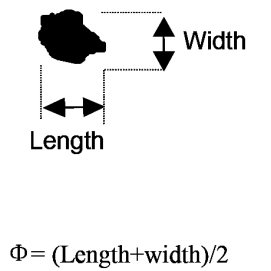
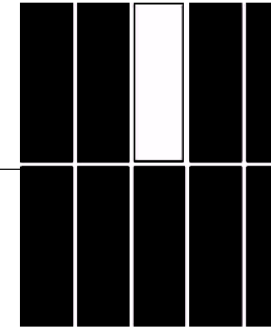
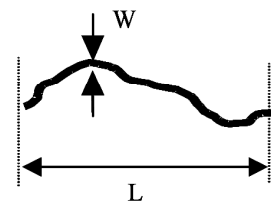
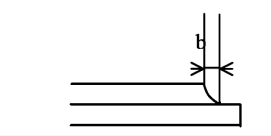
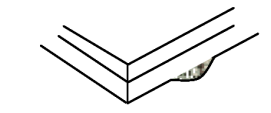
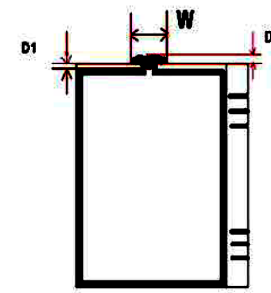
Failure mode	Illustration	Category(Unit: mm)		Acceptable count	
				Viewing area	non-Viewing area
Black spot White spot	 <p><math>\Phi = (\text{Length} + \text{width}) / 2</math></p>	A	$\Phi \leq 0.10$	Not count	Not count
		B	$0.10 < \Phi \leq 0.15$	2, The gap between the two spots should be 5 mm and above.	
		C	$0.15 < \Phi \leq 0.20$	1	
		D	$0.20 < \Phi$	0	
Bright spot (Red spot, green spot and blue spot caused by damaged colour filter)		A	Area $\leq 1$ sub-pixel	1	N/A
Black line White line		A	$W \leq 0.03$	Not count	Not count
		B	$0.03 < W \leq 0.05, L \leq 3.0$	2	
		C	$0.05 < W$	Judged by spot spec	
Below are cosmetic inspection specifications					
Excess glass		$b \leq 1.0$ , this defect shall not affect the outline dimension or assembly process. (Remarks: For COG process, the defect size is decided by the dimension of LCD panel.)			
		This defect shall not affect the outline dimension or assembly process.			
The depth of UV glue entered in LCD cell		a. $D1 \geq 0.2$ , not enter into viewing area b. $D2 \leq 0.8$ , c. $W = \text{End mouth width} + (2 \sim 6 \text{ mm})$			

Glass defect (scratch, damage)	① LCD ledge damage	Category	
		A	The defect shall not affect the outline dimension or assembly process at non ITO zone.
		B	$b \leq 1/4w$ , a & c not count (at ITO zone)
		C	Alignment mark on LCD ledge shall not be damaged.
	② Outside of perimeter damage	<p>b can't reach inside of perimeter.</p>	
③ Joint glass damage	<p>b can't reach outside of perimeter or ITO layout.</p>		
④ Corner damage	A	$a \cong t, b \cong 3.0, c \cong 3.0$	
		B. Alignment mark on LCD ledge shall not be damaged.	
<p>Remark: a stands for thickness of damage, b for width, c for length and t for glass thickness. (Unit: mm)</p>			

## 8. Packing demonstrate

No	Item	Model (Material)	Dimensions(mm)	Unit Weight(Kg)	Quantity	Remark
1	LCM module	BD070RDB10	164.90x100.00x5.7	TBD	50	
2	Partition_1	Corrugated Paper	513x333x215	2.0	1	
3.	Anti-Static Bag	PE	200x175x0.05	0.01	50	Anti-static
4	Dust-Proof Bag	PE	700x545	0.0600	1	
5	Partition_2	Corrugated Paper	505x332	0.1	2	
6	Corrugated Bar	Corrugated Paper	513x148	4		
7	Beauty-grain	Tape	30x10	TBD	50	
8	Dessicant	Dessicant	45x35	0.002	8	
9	Carton	Corrugated Paper	530x350x250	1.1000	1	
10	Total weight	TBD±5%				

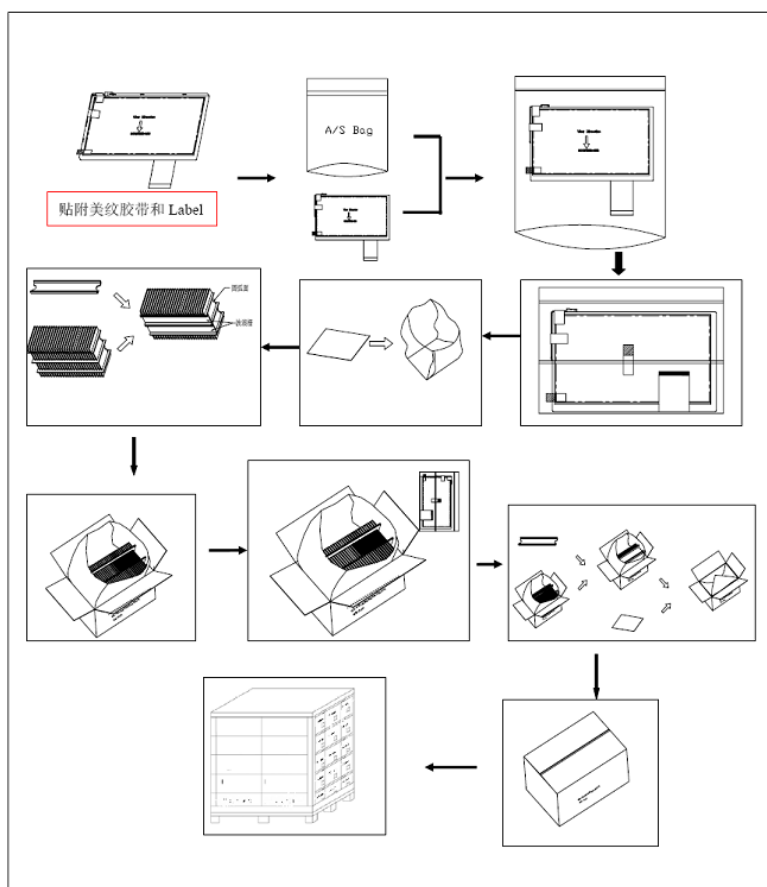

## 9. PRECAUTIONS FOR LCM

Beverly Display Solutions LCMs have been assembled and accurately calibrated before delivery. Please observe the following criteria when handling.

### 9.1 Static electricity warning

A. Do not take the LCM from its anti-static bag until it's to be assembled.

LCM's are individually packaged in bags specially treated to resist static electricity. When storing, keep the LCM packed in the original bags, or store them in a container processed to be resistant to static electricity, or in an electric conductive container.

B. Always use a ground strap when handling a LCM.

Always use a ground strap while working with the module, from the time it is taken out of the anti-static bag until it is assembled. If it is necessary to transfer the LCM, once it has been taken out of the bag, always place it in an electric conductive container. Avoid wearing clothes made of chemical fibers, the use of cotton or conductive treated fiber clothing is recommended.

C. Use a no-leak iron for soldering the LCM.

The soldering iron to be used for soldering the I/O terminals to the LCM are to be insulated or grounded at the iron tip.

D. Always ground electrical apparatuses required for assembly.

Electrical apparatuses required to assemble the LCM into a product, i.e. electrical screw drivers, are to be first grounded to avoid transmitting spike noises from the motor.

E. Assure that the work bench is properly grounded.

F. Peel off the LCM protective film slowly.

The module is attached with a film to protect the display surface from contamination, damage, adhesion of flux, etc. Peeling off this film abruptly could cause static electricity to be generated, so peel the tape slowly.

G. Pay attention to the humidity in the work area.

50~60% RH is recommended.

### 9.2 Precautions for the soldering of a LCM

The following procedures should be followed when soldering the LCM:

A. Solder only to the I/O terminal.

B. Use a no leakage soldering iron and pay particular attention to the following:

(1) Conditions for soldering I/O terminals



Temperature at iron tip: 280°C + 10°C

Soldering time: 3~4 sec/terminal

Type of solder: Eutectic solder (rosin flux filled)

Note: (Avoid using flux, because it could penetrate the module and the module may get contaminated during cleaning.) Peel off protective film after soldering the I/O terminals. By following this procedure, the surface contamination caused by the dispersion of flux while soldering can be avoided.

#### (2) Removing the wiring

(When a lead wire, or a connector to the I/O terminal of the module is to be removed, remove it only after the solder at the connection has sufficiently melted since the I/O terminal is a through hole.) If it is forcefully removed, it could cause the terminal to break or peel. The recommended procedure is to use a suction-type solder remover. Caution: do not reheat the I/O terminal more than 3 times.

### 9.3 Long-term storage

If the correct method of storage is not followed, deterioration of the display material (polarizer) and oxidation of the I/O terminal plating may make the process of soldering difficult. Please comply with the following procedure.

- A. Store in the shipping container.
- B. If the shipping container is not available, place in anti-static bags and seal the opening.
- C. Store the modules where they are not subjected to direct sunlight or a fluorescent lamp.
- D. Store in a temperature range of 0°C - 35°C with low relative humidity.

### 9.4 Precautions in use of LCD modules

- A. Do not give any external shock.
- B. Do not wipe the surface with hard materials.
- C. Do not apply excessive force on the surface.
- D. Do not expose to direct sunlight or fluorescent light for a long time.
- E. Avoid storage in high temperature and high humidity.
- F. When storage for a long time at 40°C or higher is required, R/H should be less than 60%.
- G. Liquid in LCD is hazardous substance. Do not lick, swallow when the liquid is attached to your hands, skin, clothes etc. Wash it out thoroughly.