

Beverly Display Solutions

Module No. : BD057QDB01

Revision : Ver 1.0

Customer _____

Approved By	Date	Notes

CONTENTS

No	ITEM	PAGE
1	General Description	4
2	Mechanical Specifications	4
3	Interface signals	6
4	Absolute Maximum Ratings	7
4.1	Electrical Maximum Ratings - FOR IC ONLY	7
4.2	Environmental Condition	7
5	Electrical Specifications	8
5.1	Typical Electrical Characteristics	8
5.2	TFT Panel Timing Characteristics	9
6	Optical Characteristics (for panel only)	12
7	TFT Inspection Specifications	14
8	Packing demonstrate	16
9	PRECAUTIONS FOR LCM	17

1. General Description

- 5.7", Normally Black with Anti-Glare, 16.7M Colors, MVA TFT dot matrix LCD module.
- Viewing Angle: 6 o'clock
- Logic Voltage : 3.3V(Type)
- Driving IC: HX8250A and HX8678A
- Data Interface: RGB Interface.

2. Mechanical Specifications

The mechanical detail is shown in Fig. 2 and summarized in Table 1 below.

Table 1

Parameter	Specifications	Unit
Outline dimensions	144.0(W) x 104.6(H) x 12.3(D)	mm
Color TFT 240xRGBx320	Active area	115.2(W) x 86.4(H)
	Display format	640 (RGB) x 480
	Color configuration	RGB stripe
	Dot pitch	0.18 (RGB) (W) x 0.18(H)
Weight	Approx TBD	gram

Note 1: Viewing direction for best image quality is different from TFT definition. There is a 180 degree shift.

Note 2: Requirements on Environmental Protection: Q/S0002

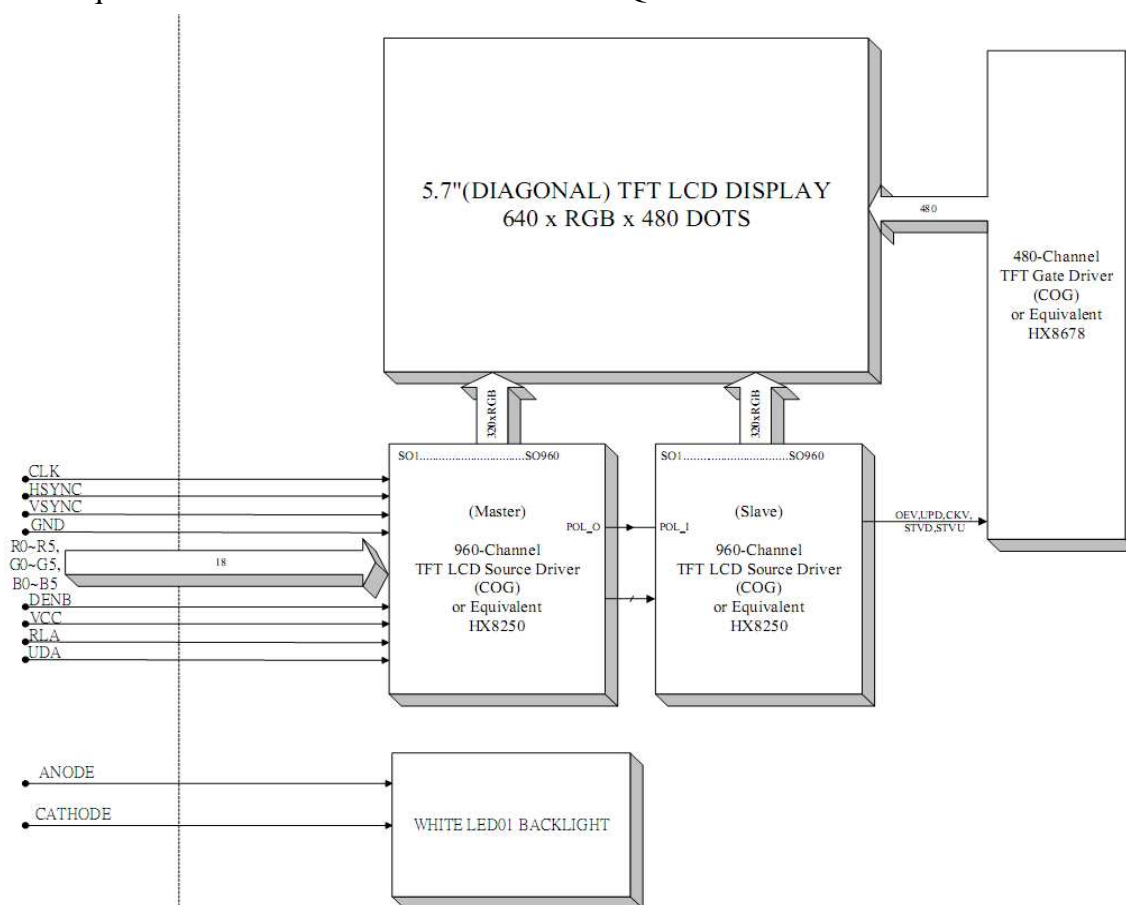

Figure 1: Block Diagram

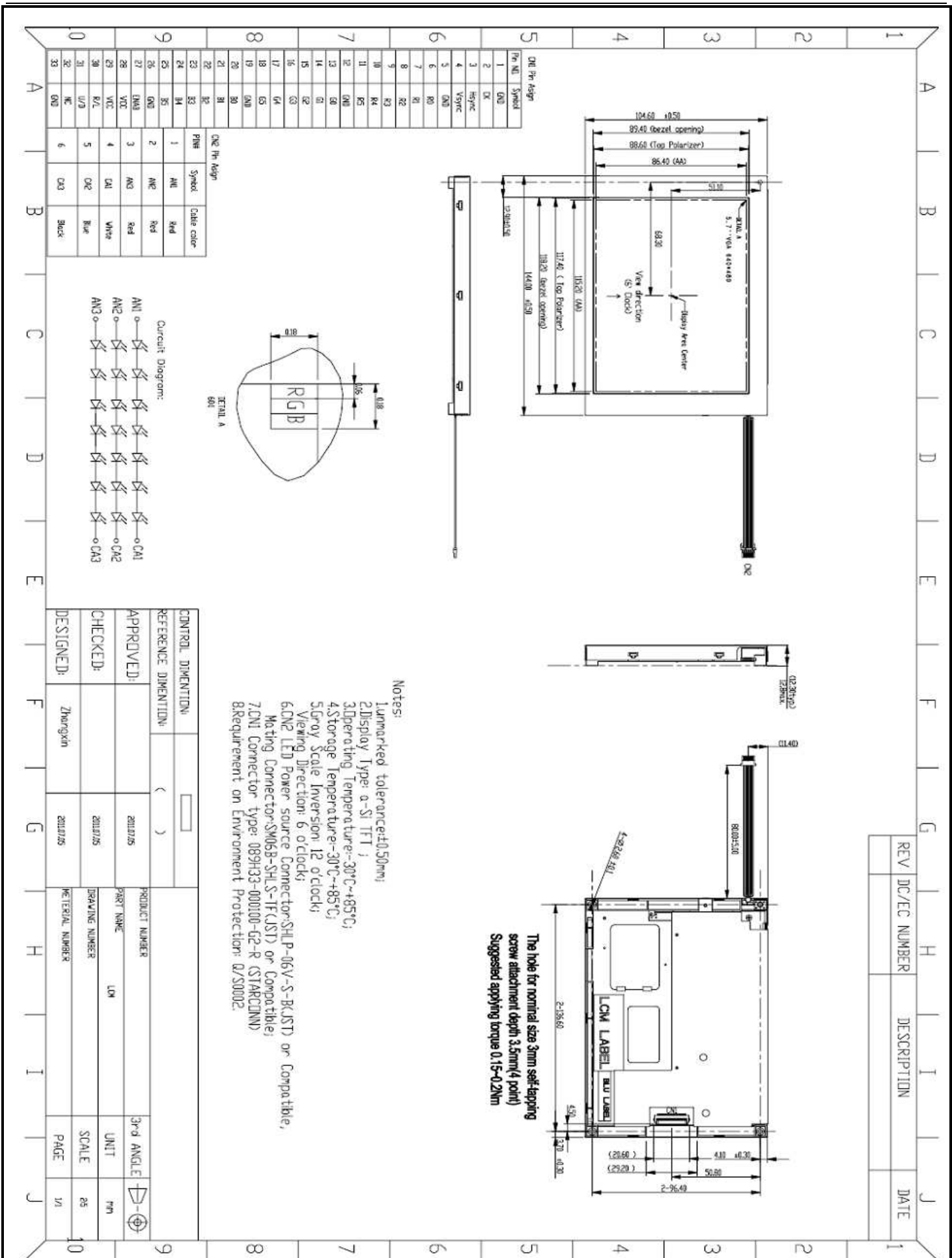

Figure 2: Module Specification

3. Interface Signals

Table 2: Pin assignment

Pin No.	Symbol	Description
1	GND	Ground.
2	DCLK	Dot Data Clock
3	HSYNC	Horizontal Synchronous Signal
4	VSYNC	Vertical Synchronous Signal
5	GND	Ground.
6~11	R0~R5	Red Data bus.
12	GND	Ground.
13~18	G0~G5	Green Data bus.
19	GND	Ground.
20~25	B0~B5	Blue Data bus.
26	GND	Ground.
27	DEN	Data Enable Signal
28,29	VDD	Power supply to the liquid crystal power supply analog circuit. Connect to an external power supply.
30	R/L	Set horizontal scan direction. Low/NC: left to right; High: right to left.
31	U/D	Set vertical scan direction. High/NC: up to down; Low: down to up.
32	NC	Dummy pin, Please let it float.
33	GND	Ground.

Connector type: SHLP-06V-S-B (JST)

No	Symbol	I/O	Description	Comment
1	AN1	P	LED driving anode 1 (high voltage)	
2	AN2	P	LED driving anode 2 (high voltage)	
3	AN3	P	LED driving anode 3 (high voltage)	
4	CA1	P	LED driving cathode 1 (low voltage)	
5	CA2	P	LED driving cathode 2 (low voltage)	
6	CA3	P	LED driving cathode 3 (low voltage)	

Note1: CN2 Matching Connector type: SM06B-SHLS-TF (JST)

4. Absolute Maximum Ratings

4.1 Electrical Maximum Ratings – for IC Only

Table 3

Parameter	Symbol	Min.	Max.	Unit
Power supply voltage (VDD)	IOVDD	-0.3	+5.0	V
Power supply voltage (VDD)	VDD	-0.3	+5.0	V
Back Light Forward Current	I _F		75	mA
Logic input voltage	V _{IN}	-0.3	IOVDD+0.5	V
Logic output voltage	V _{OUT}	-0.3	IOVDD+0.5	V

Note 1: GND =0V.

Note2: No condensation allowed under any condition.

4.2 Environmental Condition

Table 4

Item	Operating temperature (T _{opr})		Storage temperature (T _{stg}) (Note 1)		Remark
	Min.	Max.	Min.	Max.	
Ambient temperature(T _a)	-20°C	+70°C	-30°C	+85°C	Dry
Humidity (Note 1)	90% max. RH for Ta ≤ 40°C < 50% RH for 40°C < Ta ≤ Maximum operating temperature				No condensation
Vibration(IEC 68-2-6) cells must be mounted on a suitable connector	Frequency: 10 ~ 55 Hz Amplitude: 0.75 mm Duration: 20 cycles in each direction.				3 directions
Shock (IEC 68-2-27) Half -sine pulse shape	Pulse duration: 11 ms Peak acceleration: $981 \text{ m/s}^2 = 100\text{g}$ Number of shocks: 3 shocks in 3 mutually perpendicular axes.				3 directions

Note 1: Product cannot sustain at extreme storage conditions for long time.

5. Electrical Specifications

5.1 Typical Electrical Characteristics

At $T_a = 25\text{ }^\circ\text{C}$, $V_{DD}=3.3\text{V}$, $GND=0\text{V}$.

Table 5

Parameter	Symbol	Conditions	Min.	Typ.	Max.	Unit
Supply voltage	VDD		+3.0	+3.3	+3.6	V
Gate drive High voltage	VGH		-	-	-	V
Gate drive Low voltage	VGL		-	-	-	V
Input signal voltage	V_{IH}	“H” level	$0.7I_{OVDD}$	-	I_{OVD} D	V
	V_{IL}	“L” level	VSSD	-	$0.3I_{OVDD}$	V
Supply current	ICC+IVDD	IOVDD= +3.3V, Note1	-	-	-	mA
		VDD = +3.3V, Note 1	-	-	-	mA
Supply voltage of white LED backlight	VLED	Forward current =75mA(@25°C) Number of LED dies = 21	19.95	-	25.9	V

Note 1: Do not display the fixed pattern for a long time because it may develop image sticking due to the LCD structure. It should change pattern frequently. If the screen is displayed with fixed pattern, use a screen saver.

5.2 TFT Panel Timing Characteristics

5.2.1 Input Setup Timing

At Ta = 25°C, GND=0V, IOVDD=VDD=3.3V.

Table 6

Parameter	Symbol	Min	Typ	Max	Unit	Conditions
DOTCLK pulse duty	Tcwh	40%	50%	60%	Tclk	Tcph is DCLK cycle
VSYNC setup time	Tvst	10	-	-	ns	
VSYNC hold time	Tvhd	10	-	-	ns	
HSYNC setup time	Thst	10	-	-	ns	
HSYNC hold time	Thhd	10	-	-	ns	
Data setup time	Tdsu	10	-	-	ns	Rn, Gn, Bn to DCLK
Data hold time	Tdhd	10	-	-	ns	Rn, Gn, Bn to DCLK
Enable setup time	Tesu	10			ns	

Table 5.4 AC input characteristics

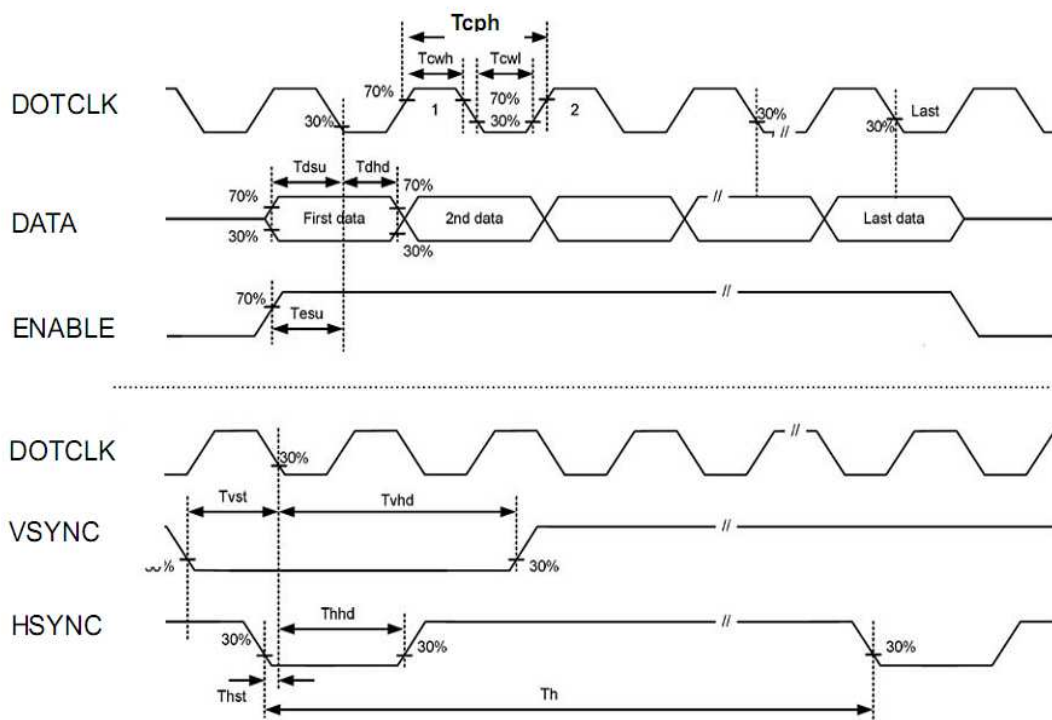

Figure 1: Input Setup Timing

5.2.2 Data Input Timing Parameter Setting

At Ta = 25°C, GND=0V, VDD=3.3V.

Table 7

Parameter	Symbol	Symbol	Min	Typ	Max	Unit
CK	Dotclk frequency	Fclk	24.8	25.2	34.2	MHz
	Dotclk cycle	Tclk	29.24	39.68	40.32	ns
Hsync	Horizontal display area	Thd	640	640	640	Tclk
	1 horizontal line	Th	800	800	1000	Tclk
	Hsync pulse width	Thpw	1	-	-	Tclk
	Horizontal blank	Thb	144	144	144	Tclk
	Horizontal front porch	Thfp	16	16	216	Tclk
Vsync	Frame rate	-	-	60	-	Hz
	Vertical display area	Tvd	480	480	480	Th
	Vsync period time	Tv	516	525	570	Th
	Vsync pulse width	Tvpw	1	-	-	Th
	Vsync blank	Tvb	35	35	35	Th
	Vsync front porch	Tvfp	1	10	55	Th

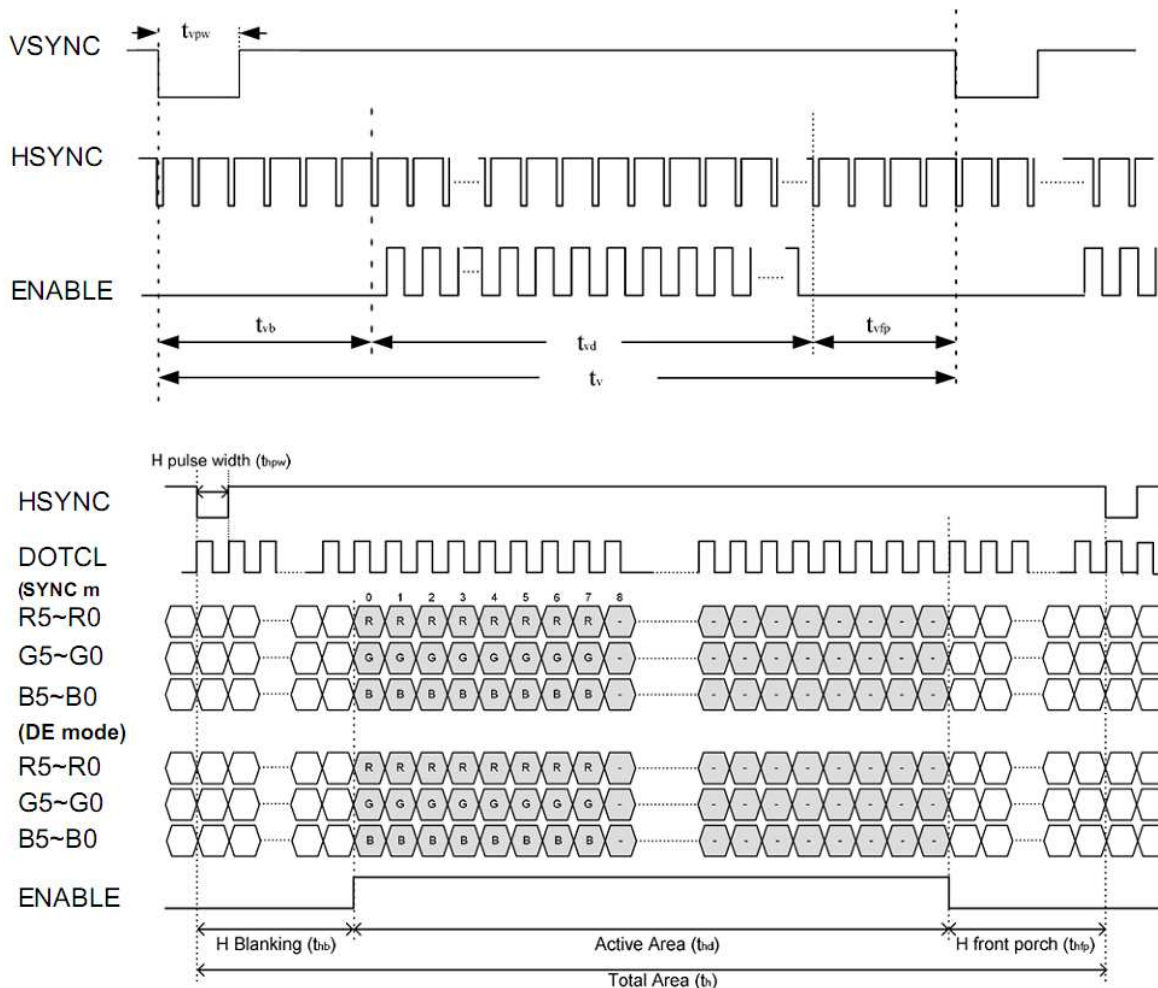

Figure 2: Data Input Timing

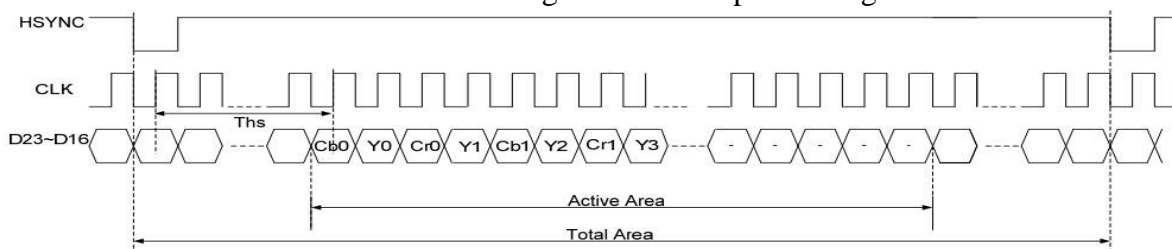

Figure 3: DE Mode Interface Characteristics

6. Optical Characteristics (for panel only)

Table 8: Optical characteristics

Items	Symbol	Condition	Min.	Typ.	Max.	Unit	Note			
Response Time	$T_R + T_F$	$T_a=25^\circ\text{C}$ Viewing normal angle $\theta=\phi=0^\circ$	-	20	30	ms	(Note 1)			
Viewing angle	12'	$T_a=25^\circ\text{C}$ Center $CR \geq 10$				deg.	(Note 2)			
	6'							1		
	9'							2		
	3'							1		
Contrast Ratio	CR	$T_a=25^\circ\text{C}$ Viewing normal angle $\theta=\phi=0^\circ$	400	500	-	-	(Note 3)			
Luminance (on the module surface)	Br	$T_a=25^\circ\text{C}$	320	400	-	cd/m^2				
Transmittance	%		-	6.5	-	%				
Chromaticity	Red	$T_a=25^\circ\text{C}$ Viewing normal angle $\theta=\phi=0^\circ$					(Note 4)			
								x_R	0.616	-
	y_R							0.353	-	
	Green							x_G	0.335	-
								y_G	0.576	-
	Blue							x_B	0.136	-
								y_B	0.126	-
	White							x_W	0.324	-
y_W		0.362	-							

Note 1: The electro-optical response time measurements shall be made as Figure 5 by switching the “data” input signal OFF and ON. The times needed for the luminance to change from 10% to 90% is T_r , and 90% to 10% is T_f .

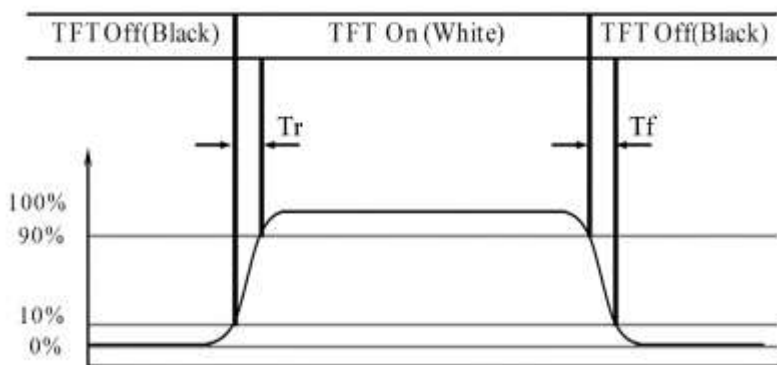

Figure 5: Response Time Testing

Note 2: The definitions of viewing angle.

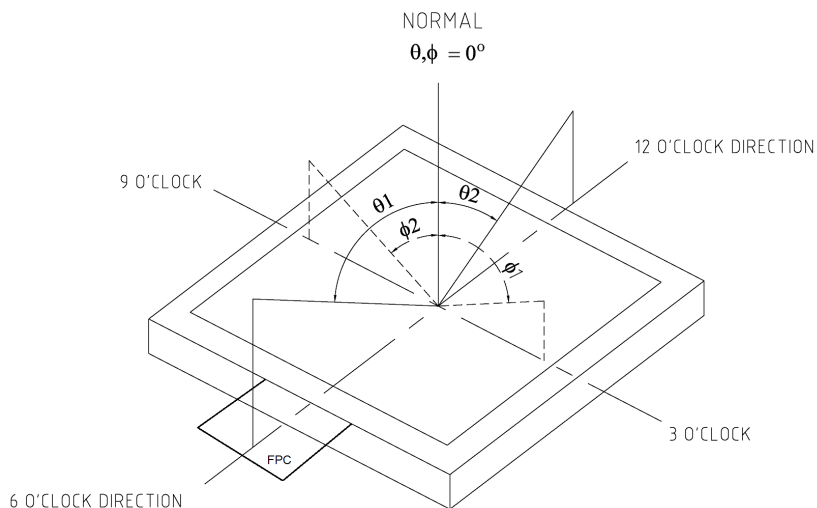

Figure 6

Note 3: Contrast measurements shall be made at viewing angle of $\theta=0^\circ$ and at the center of the LCD surface by using DMS. Luminance shall be measured with all pixels in the view field set first to white, then to the dark (black) state. (See figure 6)

Luminance Contrast Ratio (CR) is defined mathematically.

$$CR = \frac{\text{Luminance when displaying a white raster}}{\text{Luminance when displaying a black raster}}$$

Note 4: The color chromaticity coordinates specified in Table 9 shall be updated from later actual spectral data measured with all pixels first in red, green, blue and white. Measurements shall be made at the center of the panel.

7. TFT Panel Inspection Specifications

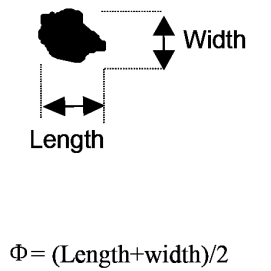
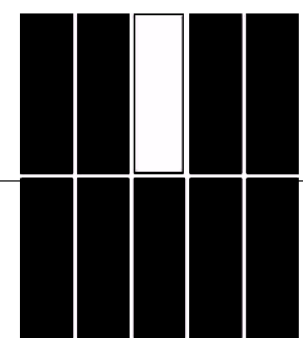
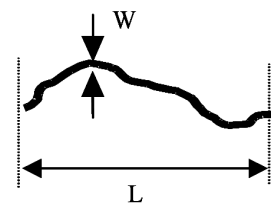
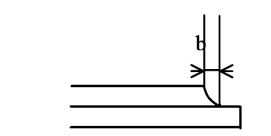
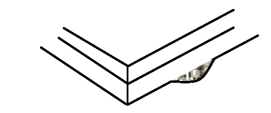
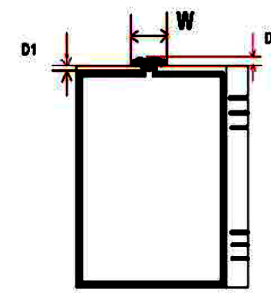
Failure mode	Illustration	Category(Unit: mm)		Acceptable count	
				Viewing area	non-Viewing area
Black spot White spot	 <p>$\Phi = (\text{Length} + \text{width}) / 2$</p>	A	$\Phi \leq 0.10$	Not count	Not count
		B	$0.10 < \Phi \leq 0.15$	2, The gap between the two spots should be 5 mm and above.	
		C	$0.15 < \Phi \leq 0.20$	1	
		D	$0.20 < \Phi$	0	
Bright spot (Red spot, green spot and blue spot caused by damaged colour filter)		A	Area ≤ 1 sub-pixel	1	N/A
Black line White line		A	$W \leq 0.03$	Not count	Not count
		B	$0.03 < W \leq 0.05, L \leq 3.0$	2	
		C	$0.05 < W$	Judged by spot spec	
Below are cosmetic inspection specifications					
Excess glass		$b \leq 1.0$, this defect shall not affect the outline dimension or assembly process. (Remarks: For COG process, the defect size is decided by the dimension of LCD panel.)			
		This defect shall not affect the outline dimension or assembly process.			
The depth of UV glue entered in LCD cell		a. $D1 \geq 0.2$, not enter into viewing area b. $D2 \leq 0.8$, c. $W = \text{End mouth width} + (2 \sim 6 \text{ mm})$			

Glass defect (scratch, damage)	① LCD ledge damage	Category	
		A	The defect shall not affect the outline dimension or assembly process at non ITO zone.
		B	$b \leq 1/4w$, a & c not count (at ITO zone)
		C	Alignment mark on LCD ledge shall not be damaged.
	② Outside of perimeter damage		
	③ Joint glass damage		
	④ Corner damage	A	$a \cong t, b \cong 3.0, c \cong 3.0$
		B. Alignment mark on LCD ledge shall not be damaged.	
<p>Remark: a stands for thickness of damage, b for width, c for length and t for glass thickness. (Unit: mm)</p>			

8. Packing demonstrate

No	Item	Model(Material)	Dimensions (mm)	Unit Weigt (Kg)	Quantity	Remark
1	LCM module	BD057QDB01	144X104.6X12.3	TBD	40	
2	Partition_1	Corrugated paper	513X333X215	1.388	1	
3	Anti-static Bag	PE	180X165X0.05	0.001	40	Anti-static
4	Dust-Proof Bag	PE	700X530	0.06	1	
5	Partition_2	Corrugated Paper	505X332X4.0	0.098	2	
6	Corrugated Bar	Corrugated paper	513X110×31	0.048	4	
7	Carton	Corrugated paper	530X350X250	1.12	1	
8	Total weight	TBD				

Note: Packaging Specification and Quantity

Module quantity in a carton: 20pcs(per row)x2(per column)= 40pcs

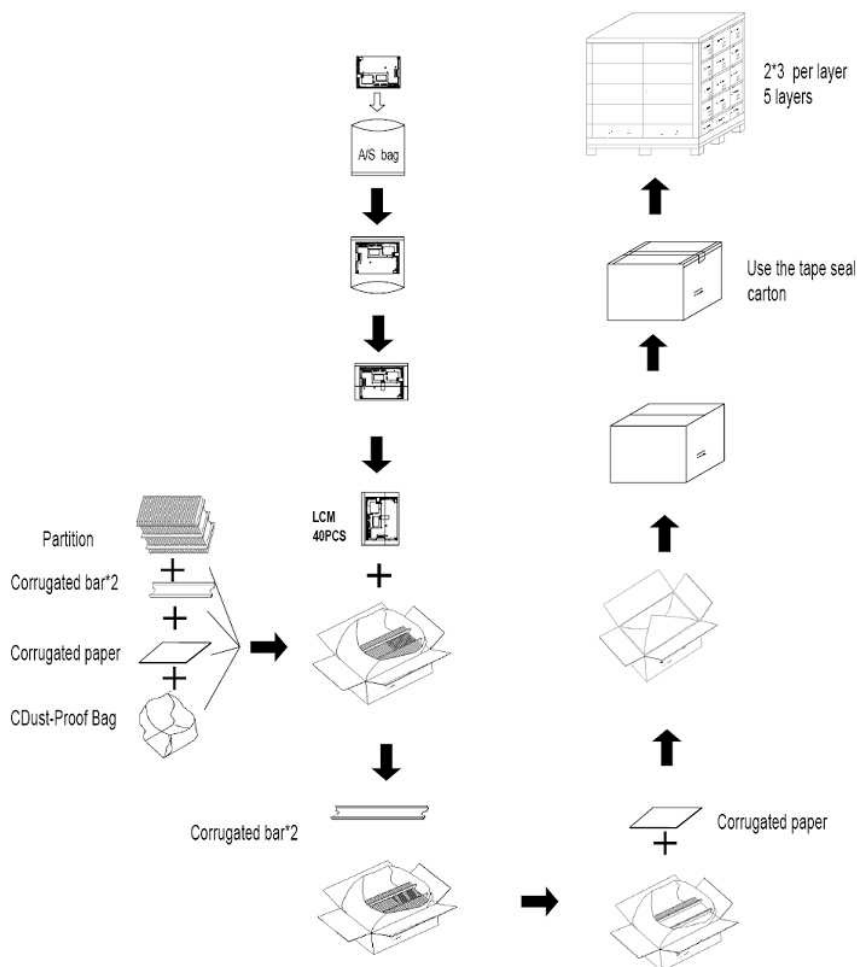

9. PRECAUTIONS FOR LCM

Beverly Display Solutions LCMs have been assembled and accurately calibrated before delivery. Please observe the following criteria when handling.

9.1 Static electricity warning

A. Do not take the LCM from its anti-static bag until it's to be assembled.

LCM's are individually packaged in bags specially treated to resist static electricity. When storing, keep the LCM packed in the original bags, or store them in a container processed to be resistant to static electricity, or in an electric conductive container.

B. Always use a ground strap when handling a LCM.

Always use a ground strap while working with the module, from the time it is taken out of the anti-static bag until it is assembled. If it is necessary to transfer the LCM, once it has been taken out of the bag, always place it in an electric conductive container. Avoid wearing clothes made of chemical fibers, the use of cotton or conductive treated fiber clothing is recommended.

C. Use a no-leak iron for soldering the LCM.

The soldering iron to be used for soldering the I/O terminals to the LCM are to be insulated or grounded at the iron tip.

D. Always ground electrical apparatuses required for assembly.

Electrical apparatuses required to assemble the LCM into a product, i.e. electrical screw drivers, are to be first grounded to avoid transmitting spike noises from the motor.

E. Assure that the work bench is properly grounded.

F. Peel off the LCM protective film slowly.

The module is attached with a film to protect the display surface from contamination, damage, adhesion of flux, etc. Peeling off this film abruptly could cause static electricity to be generated, so peel the tape slowly.

G. Pay attention to the humidity in the work area.

50~60% RH is recommended.

9.2 Precautions for the soldering of a LCM

The following procedures should be followed when soldering the LCM:

A. Solder only to the I/O terminal.

B. Use a no leakage soldering iron and pay particular attention to the following:

(1) Conditions for soldering I/O terminals

Temperature at iron tip: 280°C + 10°C

Soldering time: 3~4 sec/terminal

Type of solder: Eutectic solder (rosin flux filled)

Note: (Avoid using flux, because it could penetrate the module and the module may get contaminated during cleaning.) Peel off protective film after soldering the I/O terminals. By following this procedure, the surface contamination caused by the dispersion of flux while soldering can be avoided.

(2) Removing the wiring

(When a lead wire, or a connector to the I/O terminal of the module is to be removed, remove it only after the solder at the connection has sufficiently melted since the I/O terminal is a through hole.) If it is forcefully removed, it could cause the terminal to break or peel. The recommended procedure is to use a suction-type solder remover. Caution: do not reheat the I/O terminal more than 3 times.

9.3 Long-term storage

If the correct method of storage is not followed, deterioration of the display material (polarizer) and oxidation of the I/O terminal plating may make the process of soldering difficult. Please comply with the following procedure.

- A. Store in the shipping container.
- B. If the shipping container is not available, place in anti-static bags and seal the opening.
- C. Store the modules where they are not subjected to direct sunlight or a fluorescent lamp.
- D. Store in a temperature range of 0°C - 35°C with low relative humidity.

9.4 Precautions in use of LCD modules

- A. Do not give any external shock.
- B. Do not wipe the surface with hard materials.
- C. Do not apply excessive force on the surface.
- D. Do not expose to direct sunlight or fluorescent light for a long time.
- E. Avoid storage in high temperature and high humidity.
- F. When storage for a long time at 40°C or higher is required, R/H should be less than 60%.
- G. Liquid in LCD is hazardous substance. Do not lick, swallow when the liquid is attached to your hands, skin, clothes etc. Wash it out thoroughly.