

Beverly Display Solutions

Module No. : BD050RBB01

Revision : Ver 1.0

Customer _____

Approved By	Date	Notes

Rev	Issued Date	Description	Editor
1.0	2013-1-2	Preliminary Specification Release	

CONTENTS

No	ITEM	PAGE
1	General Description	4
2	Mechanical Specifications	4
3	Interface signals	6
4	Absolute Maximum Ratings	7
4.1	Electrical Maximum Ratings - FOR IC ONLY	7
4.2	Environmental Condition	7
5	Electrical Specifications	8
5.1	Typical Electrical Characteristics	8
5.2	TFT Panel Timing and Touch Panel Characteristics	9
6	Optical Characteristics (for panel only)	14
7	TFT Inspection Specifications	16
8	Packing demonstrate	18
9	PRECAUTIONS FOR LCM	19

1. General Description

- 5.0", Normally Black with Anti-Glare, 16.7M Colors, MVA TFT dot matrix LCD module.
- Viewing Angle: 12 o'clock
- Logic Voltage : 3.3V(Type)
- Resistor Touch Panel.
- Data Interface: RGB Interface.

2. Mechanical Specifications

The mechanical detail is shown in Fig. 2 and summarized in Table 1 below.

Table 1

Parameter	Specifications	Unit
Outline dimensions	120.7(W) x 75.8(H) x 3.0(D)	mm
Color TFT 240xRGBx320	Active area	108.0(W) x 64.8(H)
	Display format	800 (RGB) x 480
	Color configuration	RGB stripe
	Dot pitch	0.135 (RGB) (W) x 0.135(H)
Weight	Approx 76.3	gram

Note 1: Viewing direction for best image quality is different from TFT definition. There is a 180 degree shift.

Note 2: Requirements on Environmental Protection: Q/S0002

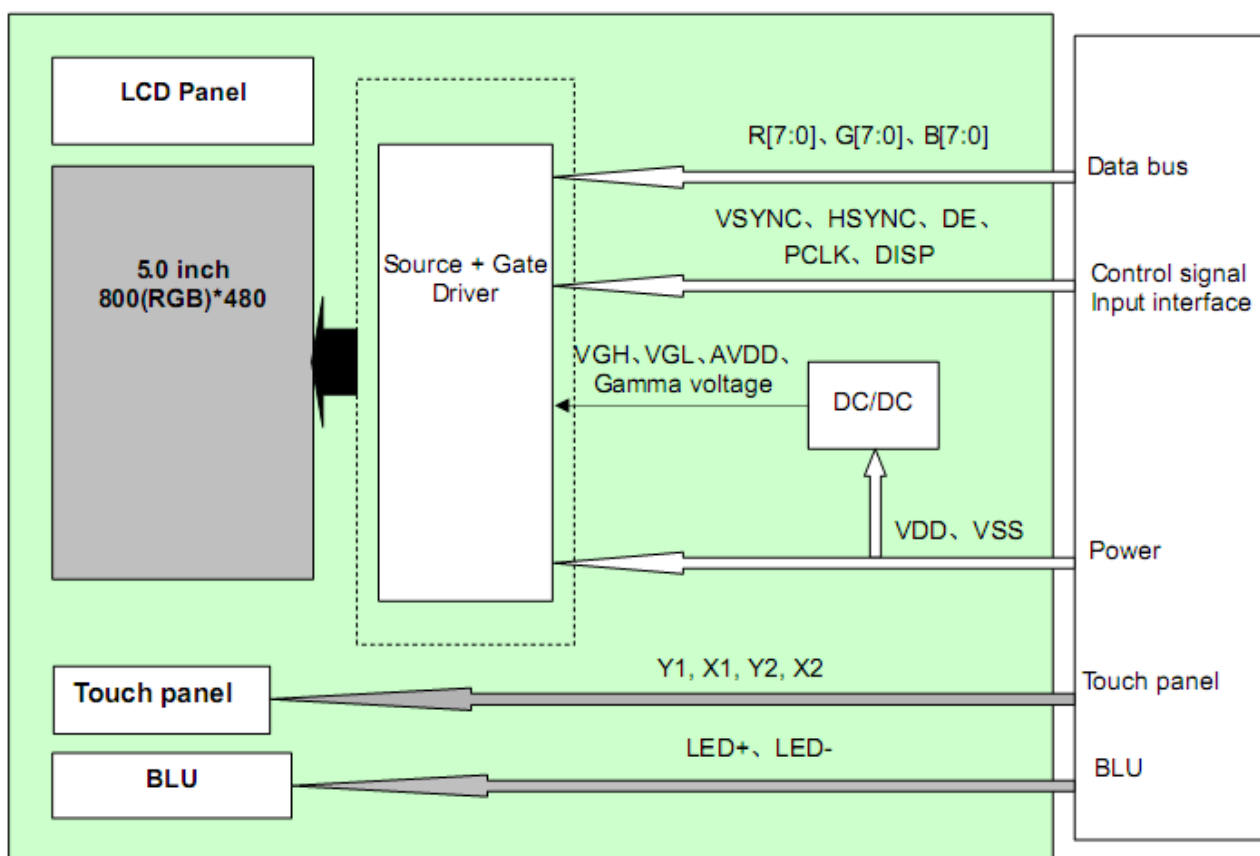
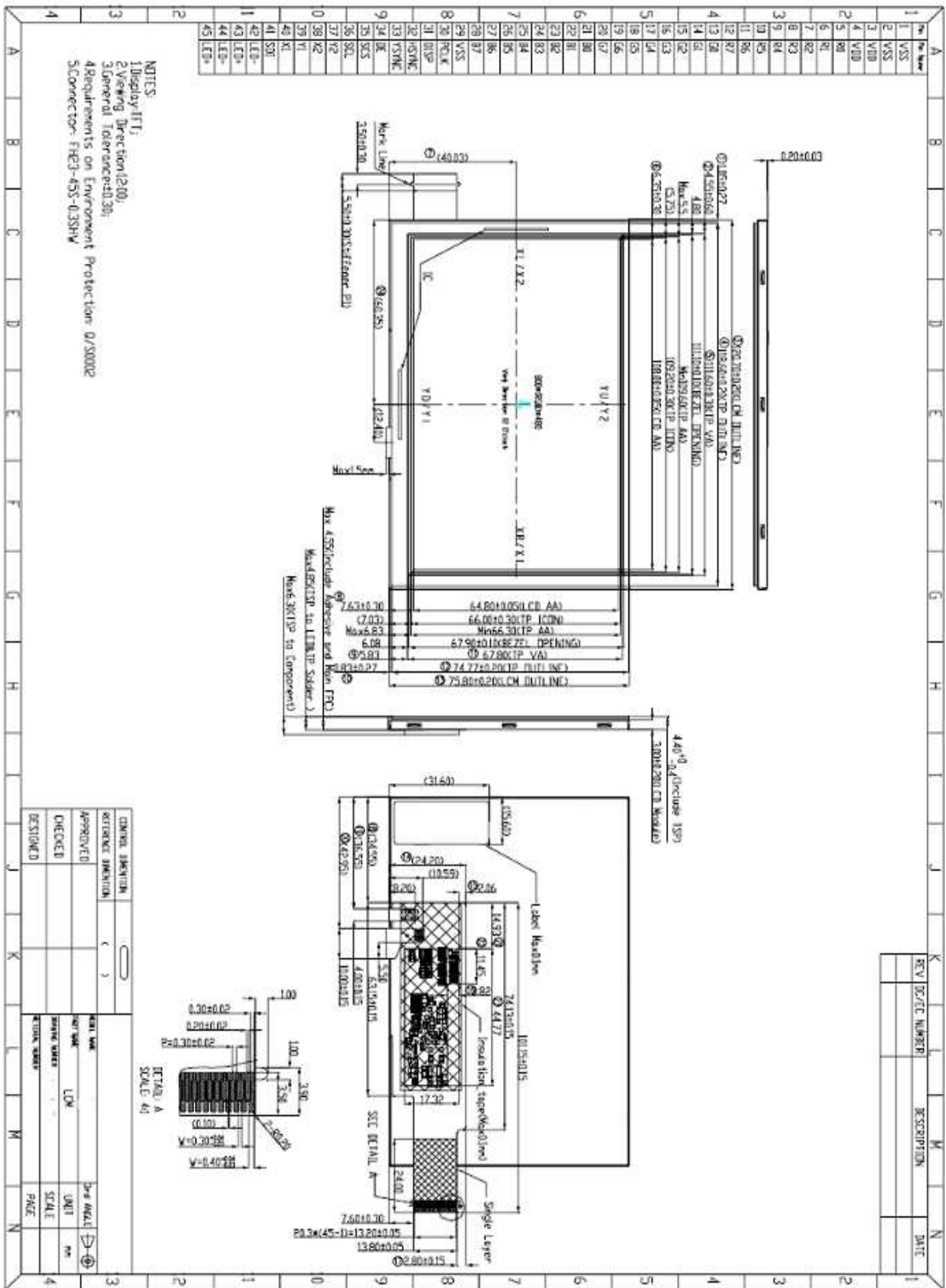

Figure 1: Block Diagram



- NOTES
- 1 Display: FTI
 - 2 Viewing Direction: 12.00
 - 3 General Tolerance: ±0.30
 - 4 Requirements on Environment Protection: 0/50002
 - 5 Connector: FH20-45S-0.35HW

CONTROL SHEET
REFERENCE DIMENSION	C	3	
APPROVED			
CHECKED			
DESIGNED			
DATE			
SCALE	1:1		
UNIT	MM		
SCALE			
PAGE			

REV	NO./EC NUMBER	DESCRIPTION	DATE

Figure 2: Module Specification

3. Interface Signals

Table 2: Pin assignment

Pin No.	Symbol	Description
1,2	GND	Ground.
3,4	VDD	Power supply to the liquid crystal power supply analog circuit. Connect to an external power supply.
5~12	R0~R7	Red Data bus.
13~20	G0~G7	Green Data bus.
21~28	B0~B7	Blue Data bus.
29	GND	Ground.
30	DCLK	Dot Data Clock
31	DISP	Standby Mode. DISP="1":Normally operation. DISP="0":Standby mode.
32	HSYNC	Horizontal Synchronous Signal
33	VSYNC	Vertical Synchronous Signal
34	DEN	Data Enable Signal
35,36	NC	Dummy pin, Please let it float.
37	XR	Touch Panel X+.
38	YD	Touch Panel Y+.
39	XL	Touch Panel X-.
40	YU	Touch Panel Y-.
41	NC	Dummy pin, Please let it float.
42	LEDK	Cathode of LED backlight.
43	LEDA	Anode of LED backlight.
44	LEDK	Cathode of LED backlight.
45	LEDA	Anode of LED backlight.

4. Absolute Maximum Ratings

4.1 Electrical Maximum Ratings – for IC Only

Table 3

Parameter	Symbol	Min.	Max.	Unit
Power supply voltage (VDD)	IOVDD	-0.3	+4.6	V
Power supply voltage (VDD)	VDD	-0.3	+4.6	V
Back Light Forward Current	I _F		25	mA
Logic input voltage	V _{IN}	-0.3	IOVDD+0.5	V
Logic output voltage	V _{OUT}	-0.3	IOVDD+0.5	V

Note 1: GND =0V.

Note2: No condensation allowed under any condition.

4.2 Environmental Condition

Table 4

Item	Operating temperature (T _{opr})		Storage temperature (T _{stg}) (Note 1)		Remark
	Min.	Max.	Min.	Max.	
Ambient temperature(T _a)	-20°C	+60°C	-30°C	+70°C	Dry
Humidity (Note 1)	90% max. RH for Ta ≤ 40°C < 50% RH for 40°C < Ta ≤ Maximum operating temperature				No condensation
Vibration(IEC 68-2-6) cells must be mounted on a suitable connector	Frequency: 10 ~ 55 Hz Amplitude: 0.75 mm Duration: 20 cycles in each direction.				3 directions
Shock (IEC 68-2-27) Half -sine pulse shape	Pulse duration: 11 ms Peak acceleration: $981 \text{ m/s}^2 = 100\text{g}$ Number of shocks: 3 shocks in 3 mutually perpendicular axes.				3 directions

Note 1: Product cannot sustain at extreme storage conditions for long time.

5. Electrical Specifications

5.1 Typical Electrical Characteristics

At Ta = 25 °C, VDD=3.3V, GND=0V.

Table 5

Parameter	Symbol	Conditions	Min.	Typ.	Max.	Unit
Supply voltage	VDD		+3.0	+3.3	+3.6	V
Gate drive High voltage	VGH		-	-	-	V
Gate drive Low voltage	VGL		-	-	-	V
Input signal voltage	V _{IH}	“H” level	0.7IOV DD	-	IOVD D	V
	V _{IL}	“L” level	VSSD	-	0.3IOV DD	V
Supply current	ICC+IVDD	IOVDD= +3.3V, Note1	-	-	-	mA
		VDD = +3.3V, Note 1	-	10	15	mA
Supply voltage of white LED backlight	VLED	Forward current =60mA(@25°C) Number of LED dies = 18	-	19.2	21	V

Note 1: Do not display the fixed pattern for a long time because it may develop image sticking due to the LCD structure. It should change pattern frequently. If the screen is displayed with fixed pattern, use a screen saver.

5.2 TFT Panel Timing and Touch Panel Characteristics

5.2.1 Input Setup Timing

At $T_a = 25^\circ\text{C}$, $\text{GND}=0\text{V}$, $\text{IOVDD}=\text{VDD}=3.3\text{V}$.

Parameter	Symb ol	Min	Typ	Max	Unit	Remark
DCLK Cycle Time	T_{pw}	66.7	-	-	ns	
DCLK Pulse High Width	T_{pwh}	26.7	-	-	ns	
DCLK Pulse Low Width	T_{pwl}	26.7	-	-	ns	
DE Setup Time	T_{des}	10	-	-	ns	
DE Hold Time	T_{deh}	10	-	-	ns	
HSYNC Setup Time	T_{hs}	10	-	-	ns	
HSYNC Hold Time	T_{hh}	10	-	-	ns	
VSYNC Setup Time	T_{vhs}	10	-	-	ns	
VSYNC Hold Time	T_{vhh}	10	-	-	ns	
Data Setup Time	T_{ds}	10	-	-	ns	
Data Hold Time	T_{dh}	10	-	-	ns	
DISP Setup Time	T_{dis}	10	-	-	us	
DISP Hold Time	T_{dish}	10	-	-	ms	

Note 1: $t_r=t_f=2\text{ns}$, t_r , t_f is defined 10% to 90% of signal amplitude.

Note 2: For parallel interface, maximum clock frequency is 15MHz.

Table 6

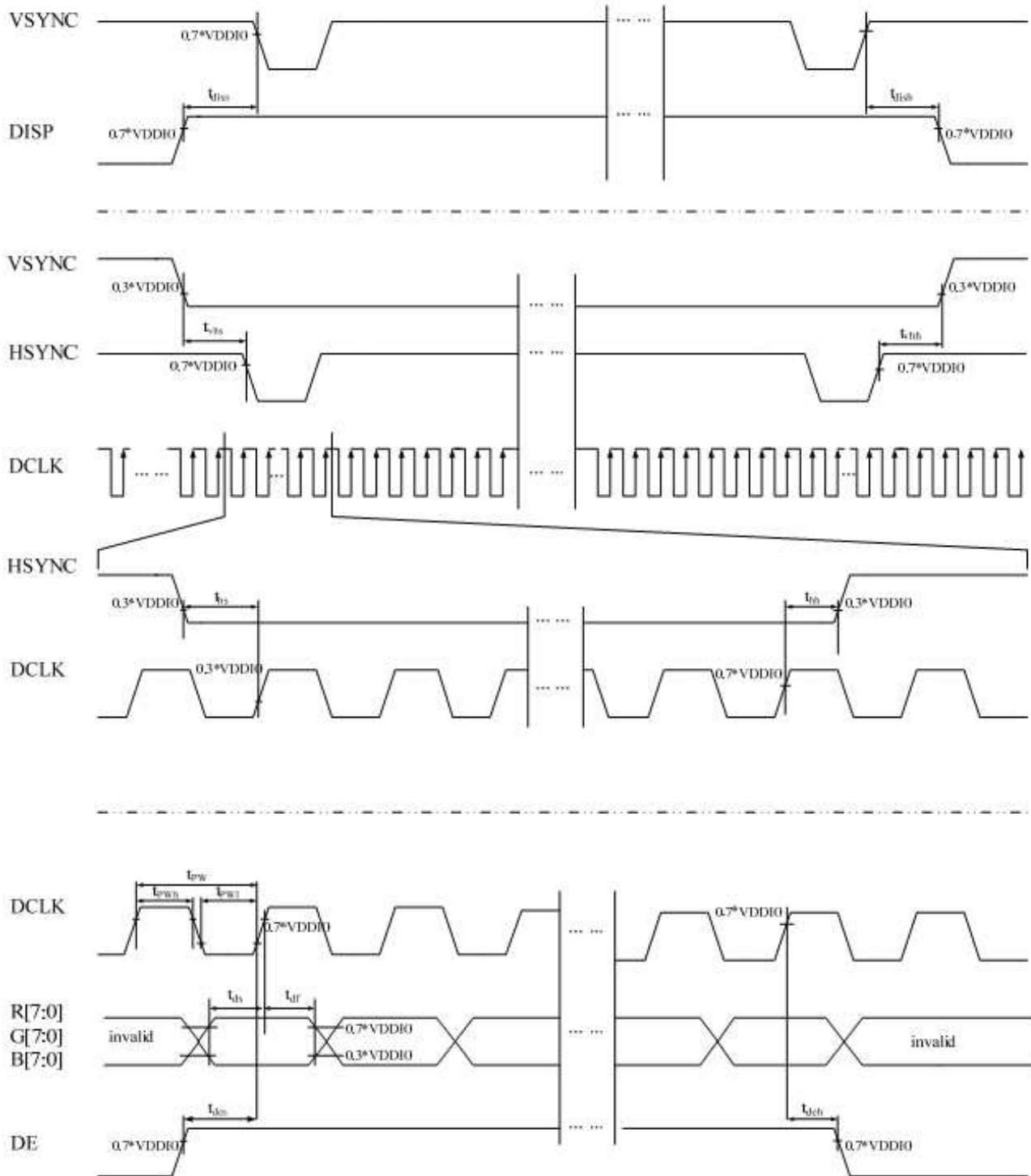

Figure 1: Input Setup Timing

5.2.2 Data Input Timing Parameter Setting

At Ta = 25°C, GND=0V, VDD=3.3V.

Table 7

Parameter	Symbol	Spec.			Unit
		Min.	Typ.	Max.	
DCLK frequency	f_{clk}	-	9	15	MHZ
HSYNC frequency	$1/t_h$	-	17.14	-	KHz
VSYNC frequency	$1/t_v$	-	59.94	-	Hz
Horizontal cycle	t_h	525	525	605	DCLK
Horizontal display period	t_{hd}	480			DCLK
Horizontal pulse width	t_{hp}	2	41	41	DCLK
Horizontal back porch	t_{hb}	2	2	41	DCLK
Horizontal front porch	t_{hf}	2	2	82	DCLK
Vertical cycle	t_v	285	286	399	HSYNC
Vertical display period	t_{vd}	272			HSYNC
Vertical pulse width	t_{vp}	1	10	11	HSYNC
Vertical back porch	t_{vb}	1	2	11	HSYNC
Vertical front porch	t_{vf}	1	2	227	HSYNC

Note 1: Unit: CLK=1/ f_{CLK} , H= t_h .

Note 2: It is necessary to keep $t_{vp}+t_{vb}=12$ and $t_{hp}+t_{hb}=43$ in sync mode. DE mode is unnecessary to keep it.

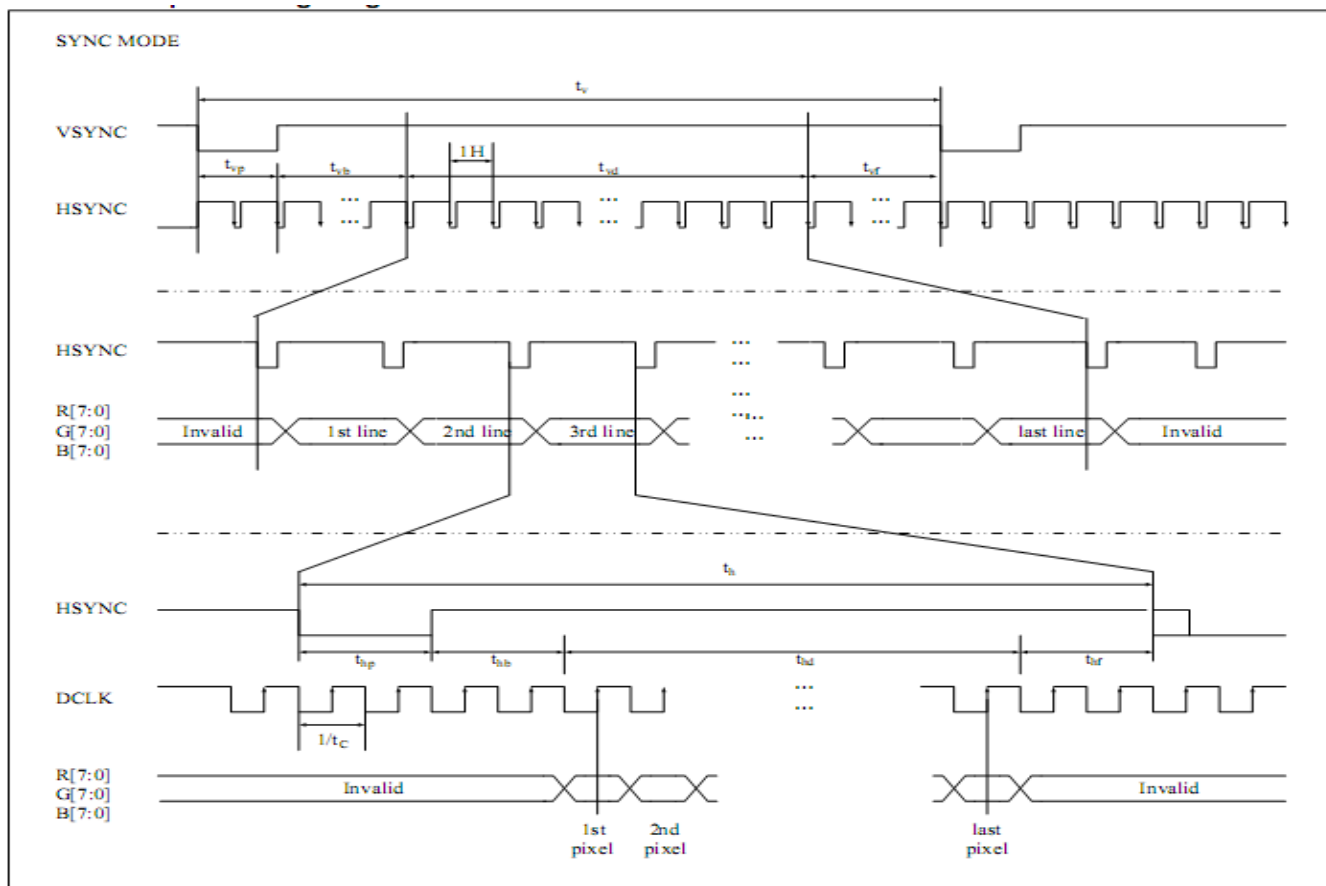

Figure 2: Data Input Timing

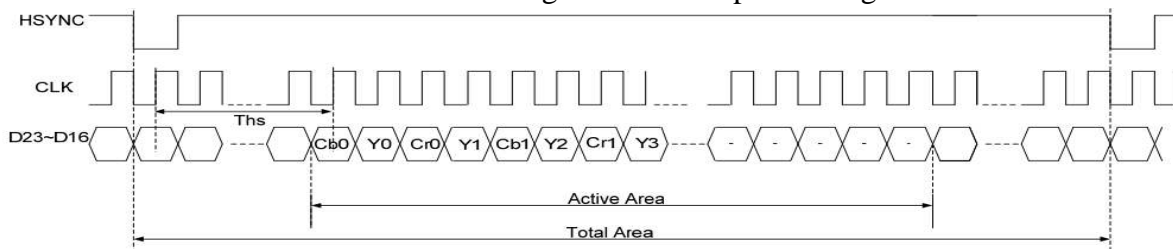

Figure 3: DE Mode Interface Characteristics

5.2.3 Touch Screen Panel Specifications

5.2.3.1 Electrical Characteristics

Item	Min.	Typ.	Max.	Unit	
Linearity	---	---	1.5%	---	Each axis: X and Y
Operating Voltage	---	5.0	10.0	V	DC
Resistance	X axis:	480	---	1100	Ω
	Y axis:	120	---	450	Ω
Chattering Time	---	---	10.0	ms	
Insulation Resistance	20	---	---	M Ω	@DC25V

5.2.3.2 Touch Panel Mechanical & Reliability Characteristics

Item	Value			Unit	Remark
	Min	Typ	Max		
Activation	80	-	160	gf	Note 1
Durability-surface scratching	Write 100000	-	-	characters	Note 2
Durability-surface pitting	1000000	-	-	touches	Note 3
Surface hardness	3			H	JIS K5400

Note1:

1. Input DC 5V on X direction , Drop off Polyacetal Stylus(R0.8),until output voltage stabilize ,then get the activation force;
2. R8 Silicon rubber for finger Activation force test;
3. Test point: 9 points。

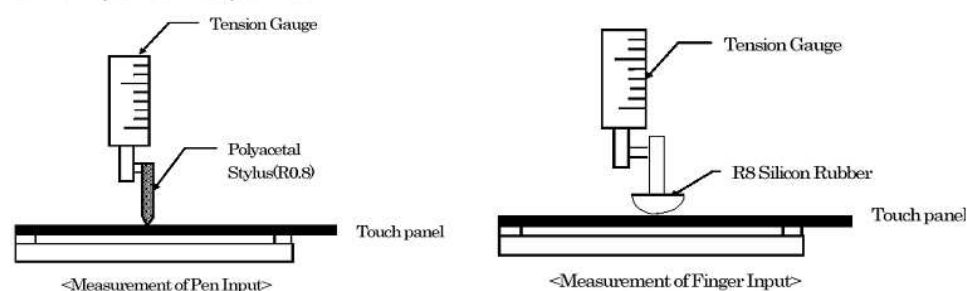

Note2:

- End shape: R0.8mm(Stylus)
- Load force: 150gf
- Writing speed: 60 mm/sec
- Material of Pen: Polyacetal resin
- Sliding length: 10~100 mm

Note3:

- End shape: R8.0mm, Material of Pen: Silicon rubber
- Hardness: 60°
- Load force: 100gf
- Frequency: 2 Hz

5.2.3.3 Electrical Characteristic Linearity Definition

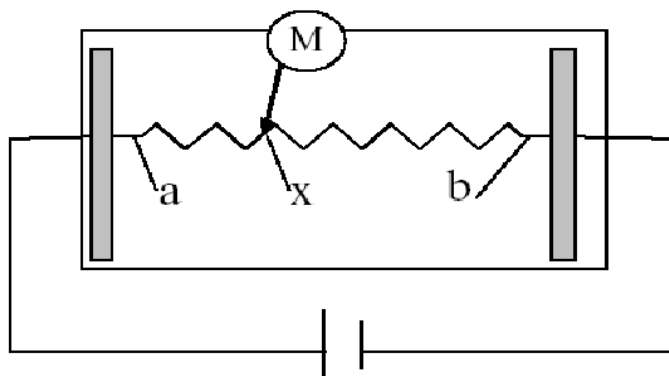

Va: maximum voltage in the active area of touch panel
 Vb: minimum voltage in the active area of touch panel
 X: random measuring point
 Vxm: actual voltage of Lx point
 Vxi: theoretical voltage of Lx point

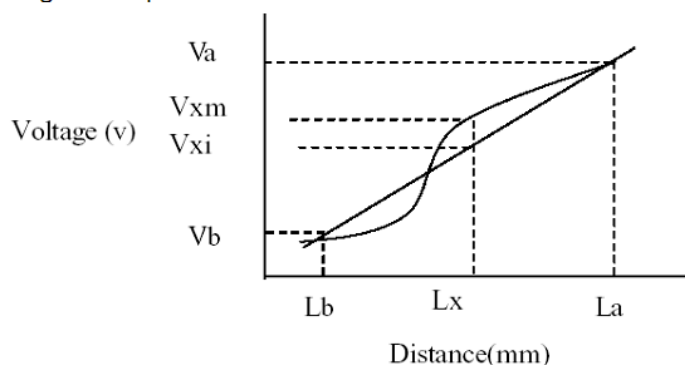

$$\text{Linearity} = \frac{|Vxi - Vxm|}{(Va - Vb)} * 100\%$$

Note: Test area is as follows and operation force is 150gf(single layer ITO Film), polyacetal stylus: R0.8mm.

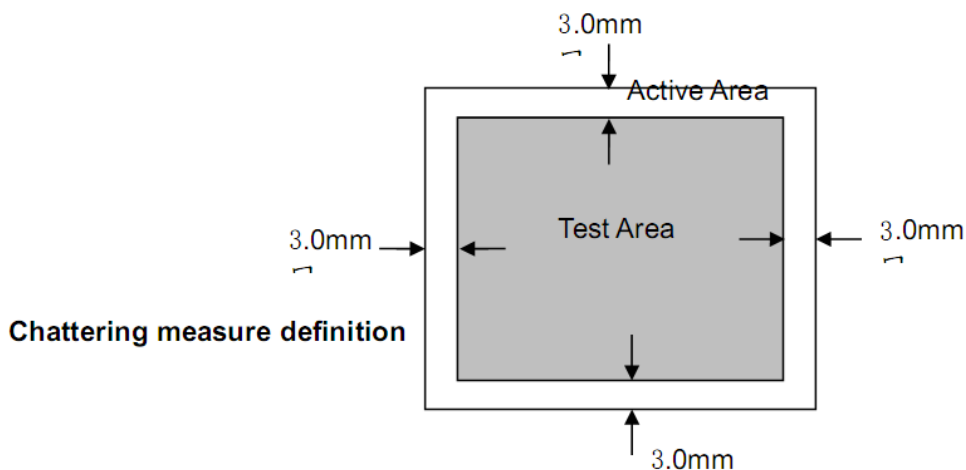

6. Optical Characteristics (for panel only)

Table 8: Optical characteristics

Items	Symbol	Condition	Min.	Typ.	Max.	Unit	Note			
Response Time	$T_R + T_F$	$T_a=25^\circ\text{C}$ Viewing normal angle $\theta=\phi=0^\circ$	-	20	30	ms	(Note 1)			
Viewing angle	12'	$T_a=25^\circ\text{C}$ Center $CR \geq 10$				deg.	(Note 2)			
	6'							2		
	9'							1		
	3'							2		
Contrast Ratio	CR	$T_a=25^\circ\text{C}$ Viewing normal angle $\theta=\phi=0^\circ$	400	450	-	-	(Note 3)			
Luminance (on the module surface)	Br	$T_a=25^\circ\text{C}$	250	300	-	cd/m^2				
Transmittance	%		-	6.5	-	%				
Chromaticity	Red	$T_a=25^\circ\text{C}$ Viewing normal angle $\theta=\phi=0^\circ$					(Note 4)			
								x_R	0.590	-
	y_R							0.350	-	
	Green							x_G	0.348	-
								y_G	0.580	-
	Blue							x_B	0.150	-
								y_B	0.100	-
	White							x_W	0.320	-
y_W		0.340	-							

Note 1: The electro-optical response time measurements shall be made as Figure 5 by switching the “data” input signal OFF and ON. The times needed for the luminance to change from 10% to 90% is T_r , and 90% to 10% is T_f .

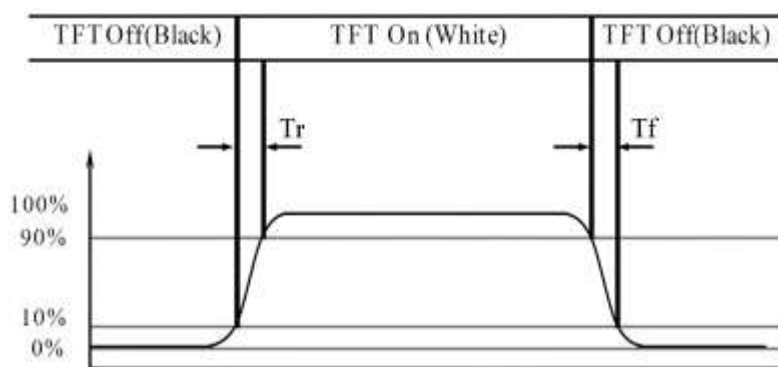

Figure 5: Response Time Testing

Note 2: The definitions of viewing angle.

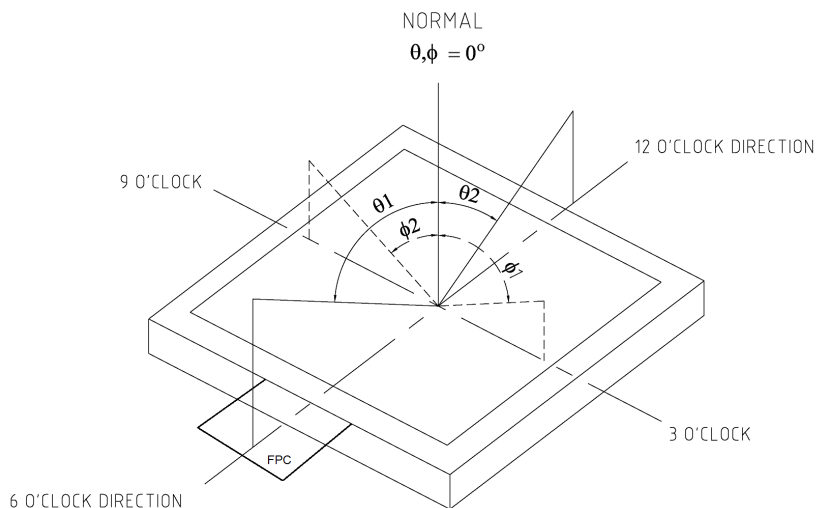

Figure 6

Note 3: Contrast measurements shall be made at viewing angle of $\theta=0^\circ$ and at the center of the LCD surface by using DMS. Luminance shall be measured with all pixels in the view field set first to white, then to the dark (black) state. (See figure 6)

Luminance Contrast Ratio (CR) is defined mathematically.

$$CR = \frac{\text{Luminance when displaying a white raster}}{\text{Luminance when displaying a black raster}}$$

Note 4: The color chromaticity coordinates specified in Table 9 shall be updated from later actual spectral data measured with all pixels first in red, green, blue and white. Measurements shall be made at the center of the panel.

7. TFT Panel Inspection Specifications

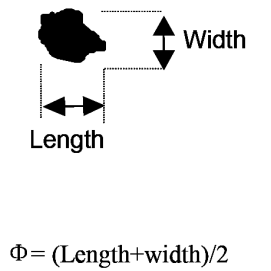
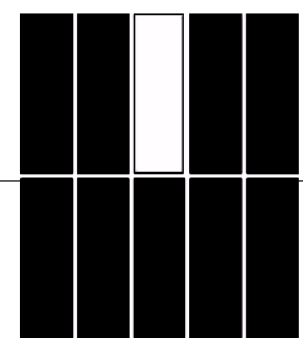
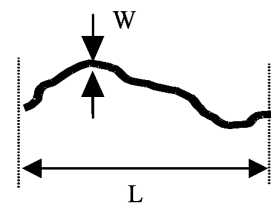
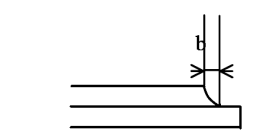
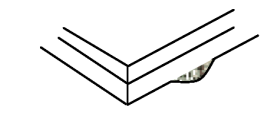
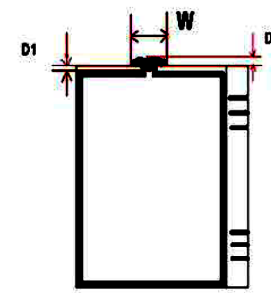
Failure mode	Illustration	Category(Unit: mm)		Acceptable count	
				Viewing area	non-Viewing area
Black spot White spot	 <p>$\Phi = (\text{Length} + \text{width}) / 2$</p>	A	$\Phi \leq 0.10$	Not count	Not count
		B	$0.10 < \Phi \leq 0.15$	2, The gap between the two spots should be 5 mm and above.	
		C	$0.15 < \Phi \leq 0.20$	1	
		D	$0.20 < \Phi$	0	
Bright spot (Red spot, green spot and blue spot caused by damaged colour filter)		A	Area ≤ 1 sub-pixel	1	N/A
Black line White line		A	$W \leq 0.03$	Not count	Not count
		B	$0.03 < W \leq 0.05, L \leq 3.0$	2	
C		$0.05 < W$	Judged by spot spec		
Below are cosmetic inspection specifications					
Excess glass		$b \leq 1.0$, this defect shall not affect the outline dimension or assembly process. (Remarks: For COG process, the defect size is decided by the dimension of LCD panel.)			
		This defect shall not affect the outline dimension or assembly process.			
The depth of UV glue entered in LCD cell		a. $D1 \geq 0.2$, not enter into viewing area b. $D2 \leq 0.8$, c. $W = \text{End mouth width} + (2 \sim 6 \text{ mm})$			

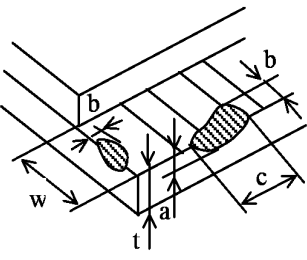
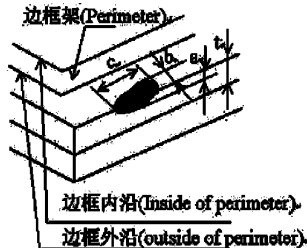
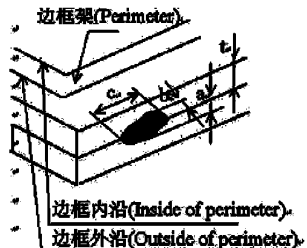
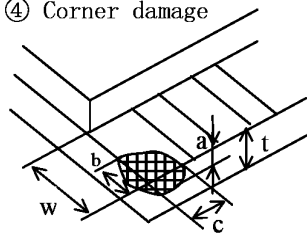
Glass defect (scratch, damage)	① LCD ledge damage	Category	
		A	The defect shall not affect the outline dimension or assembly process at non ITO zone.
		B	$b \leq 1/4w$, a & c not count (at ITO zone)
		C	Alignment mark on LCD ledge shall not be damaged.
② Outside of perimeter damage			b can't reach inside of perimeter.
③ Joint glass damage			b can't reach outside of perimeter or ITO layout.
④ Corner damage		A	$a \cong t$, $b \cong 3.0$, $c \cong 3.0$
B. Alignment mark on LCD ledge shall not be damaged.			
<p>Remark: a stands for thickness of damage, b for width, c for length and t for glass thickness. (Unit: mm)</p>			

8. Packing demonstrate

No	Item	Model (Material)	Dimensions(mm)	Unit Weight(Kg)	Quantity	Remark
1	LCM module	BD050RBB01	120.70*75.80*4.40mm	0.0763	150	
2	Tray	PET (Transmit)	485*330*14.8mm	0.166	18	
3	EPE	EPE	485*330*5	0.08	3	
4	Anti-static bag	PE	700*545mm	0.046	1	
5	BOX	CORRUGATED PAPER	520X345X74	0.44	3	
6	Desiccant	Desiccant	45×50	0.002	6	
7	Carton	CORRUGATED PAPER	544×365×250	1.01	1	
8	Total weight		17.07 Kg			

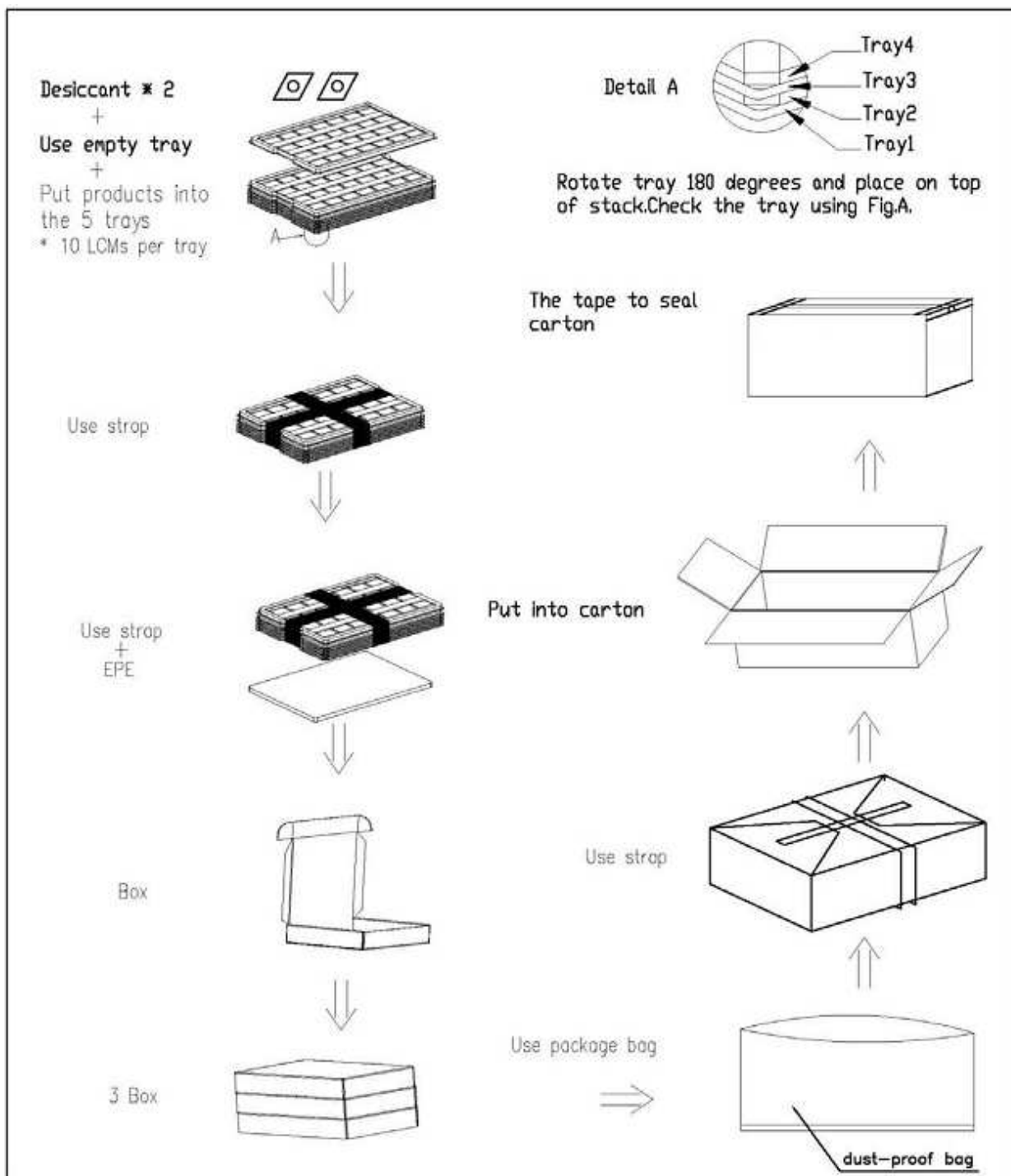

9. PRECAUTIONS FOR LCM

Beverly Display Solutions LCMs have been assembled and accurately calibrated before delivery. Please observe the following criteria when handling.

9.1 Static electricity warning

A. Do not take the LCM from its anti-static bag until it's to be assembled.

LCM's are individually packaged in bags specially treated to resist static electricity. When storing, keep the LCM packed in the original bags, or store them in a container processed to be resistant to static electricity, or in an electric conductive container.

B. Always use a ground strap when handling a LCM.

Always use a ground strap while working with the module, from the time it is taken out of the anti-static bag until it is assembled. If it is necessary to transfer the LCM, once it has been taken out of the bag, always place it in an electric conductive container. Avoid wearing clothes made of chemical fibers, the use of cotton or conductive treated fiber clothing is recommended.

C. Use a no-leak iron for soldering the LCM.

The soldering iron to be used for soldering the I/O terminals to the LCM are to be insulated or grounded at the iron tip.

D. Always ground electrical apparatuses required for assembly.

Electrical apparatuses required to assemble the LCM into a product, i.e. electrical screw drivers, are to be first grounded to avoid transmitting spike noises from the motor.

E. Assure that the work bench is properly grounded.

F. Peel off the LCM protective film slowly.

The module is attached with a film to protect the display surface from contamination, damage, adhesion of flux, etc. Peeling off this film abruptly could cause static electricity to be generated, so peel the tape slowly.

G. Pay attention to the humidity in the work area.

50~60% RH is recommended.

9.2 Precautions for the soldering of a LCM

The following procedures should be followed when soldering the LCM:

A. Solder only to the I/O terminal.

B. Use a no leakage soldering iron and pay particular attention to the following:

(1) Conditions for soldering I/O terminals

Temperature at iron tip: 280°C + 10°C

Soldering time: 3~4 sec/terminal

Type of solder: Eutectic solder (rosin flux filled)

Note: (Avoid using flux, because it could penetrate the module and the module may get contaminated during cleaning.) Peel off protective film after soldering the I/O terminals. By following this procedure, the surface contamination caused by the dispersion of flux while soldering can be avoided.

(2) Removing the wiring

(When a lead wire, or a connector to the I/O terminal of the module is to be removed, remove it only after the solder at the connection has sufficiently melted since the I/O terminal is a through hole.) If it is forcefully removed, it could cause the terminal to break or peel. The recommended procedure is to use a suction-type solder remover. Caution: do not reheat the I/O terminal more than 3 times.

9.3 Long-term storage

If the correct method of storage is not followed, deterioration of the display material (polarizer) and oxidation of the I/O terminal plating may make the process of soldering difficult. Please comply with the following procedure.

- A. Store in the shipping container.
- B. If the shipping container is not available, place in anti-static bags and seal the opening.
- C. Store the modules where they are not subjected to direct sunlight or a fluorescent lamp.
- D. Store in a temperature range of 0°C - 35°C with low relative humidity.

9.4 Precautions in use of LCD modules

- A. Do not give any external shock.
- B. Do not wipe the surface with hard materials.
- C. Do not apply excessive force on the surface.
- D. Do not expose to direct sunlight or fluorescent light for a long time.
- E. Avoid storage in high temperature and high humidity.
- F. When storage for a long time at 40°C or higher is required, R/H should be less than 60%.
- G. Liquid in LCD is hazardous substance. Do not lick, swallow when the liquid is attached to your hands, skin, clothes etc. Wash it out thoroughly.